

OPERATOR AND INSTALLATION MANUAL



Tron AIS TR-8000

AIS Class A transponder



www.jotron.com

Table of Contents

1	Revision History	6
2	Software revisions.....	6
3	Introduction	7
3.1	Safety Instructions.....	7
3.2	Compass Safe Distance	7
3.3	Copyright Notice.....	7
3.4	Disclaimer Notice	8
3.5	Disposal Instructions	8
3.6	Software and Hardware revisions.....	8
3.7	Ingress protection	8
4	Operation general introduction.....	9
4.1	About AIS in general.....	9
5	Equipment List	10
5.1	Standard Supply	10
5.2	Optional Supply	10
6	TR-8000 Description	11
6.1	Functionality.....	12
6.2	Transponder Unit	13
6.2.1	LED Indicators:	14
6.2.2	Main functionality:.....	14
6.2.3	VHF Antenna Connector	14
6.2.4	GPS Antenna Connector.....	14
6.2.5	External Display (Ethernet) Connector	15
6.2.6	Multipurpose Cable Glands.....	15
6.3	Display Unit	16
7	Operational description	17
7.1	On/Off button	17
7.1.1	Clean Screen.....	17
7.1.2	Power off Display	18
7.2	Display Unit menu system.....	19
7.2.1	Status Bar	19
7.2.2	Content Section.....	20
7.2.3	Button Bar	20
7.2.4	Important Buttons shown in different Views:	21

7.2.5	Indicating ICONS.....	22
7.2.6	Ship List	23
7.2.6.1	Column description.....	24
7.2.7	Graphical View	25
7.3	Voyage Settings	27
7.3.1	Navigational Status	28
7.3.2	Destination.....	29
7.3.3	ETA	30
7.3.4	Persons Aboard (optional)	30
7.3.5	Cargo Category.....	30
7.3.6	Draught	31
7.4	Messages	32
7.4.1	Received messages	32
7.4.2	Popup when received message	33
7.4.3	Sent messages.....	33
7.4.4	Write New message	34
7.4.4.1	Message recipients "From list"	35
7.4.4.2	Message recipients "Enter MMSI"	36
7.4.4.3	Message recipients "Broadcast"	36
7.5	Display Settings	37
8	Installation.....	38
8.1	Mechanical Mounting	38
8.1.1	Transponder unit.....	38
8.1.2	Display Unit	39
8.1.2.1	Desktop Mounting	39
8.1.2.2	Roof Mounting.....	40
8.1.2.3	Flush/ Panel Mounting	41
8.1.3	Antennas	42
8.1.3.1	GPS Antenna	43
8.1.3.2	VHF Antenna.....	44
8.2	Cabling.....	45
8.2.1	GPS antenna.....	45
8.2.2	VHF antenna.....	46
8.2.3	Cable between Transponder and Display Unit	46
8.3	Wiring and Connections	47
8.3.1	Transponder.....	48
8.3.1.1	Pictorial display of typical connections to the transponder	49

8.3.1.2	Label in transponder with connection tables	50
8.3.1.3	Power connection	51
8.3.1.4	Sensor connections.....	52
8.3.1.5	External display – ECDIS/Radar connections	53
8.3.1.6	Pilot / Aux. Display connection	54
8.3.1.7	Alarm Connection	55
8.3.1.8	Detailed description of connections, fuses, factory reset etc.	56
8.3.2	Display Unit:	58
9	Initial configuration.....	61
9.1	Short reference for initial configuration	61
9.2	Not all ships carry AIS.....	61
9.3	Use of AIS in collision avoidance.....	61
9.4	Erroneous information.....	62
10	Operation Instructions	63
10.1	Configuration Menu	63
10.1.1	Own Ship	63
10.1.1.1	Type of Vessel	64
10.1.1.2	Ship Dimension and Antenna Position	65
10.1.2	Display Settings.....	66
10.1.2.1	Sleeping Targets.....	66
10.1.2.2	Views	66
10.1.3	Regional Settings.....	67
10.1.3.1	Current Region settings	67
10.1.3.2	View Regions	68
10.1.3.3	Add Region.....	69
10.1.3.4	Alarms.....	75
10.1.3.5	Alarm Relay Output	79
10.1.4	Indicators	80
10.2	Advanced Menu	81
10.2.1	Interface.....	81
10.2.1.1	Display/ Transponder IP	82
10.2.1.2	External display.....	83
10.2.1.3	Aux. Display/Pilot Port.....	84
10.2.1.4	Baud rate	85
10.2.1.5	Priorities.....	86
10.2.1.6	Port Monitor	87

10.2.2	VHF link/Long Range	88
10.2.2.1	Autonomous Long Range.....	88
10.2.2.2	Polled Long Range	88
10.2.2.3	Silent mode.....	89
10.2.2.4	Display SART in TEST mode.....	89
10.2.2.5	Test Communication.....	90
10.2.3	CPA/TCPA settings.....	91
10.2.4	Internal GPS	92
10.2.5	History Log	93
10.2.6	Self Test.....	94
10.2.7	System.....	95
10.2.7.1	Change password.....	95
10.2.7.2	Update Firmware.....	95
10.2.8	Current position	96
11	Menu tree	97
12	List of VHF Channels.....	98
13	Complied Standards	99
14	Outline Drawings	100
14.1	TR-8000 Transponder Unit.....	100
14.2	TR-8000 Display Unit, Desktop or Overhead mount.....	101
14.3	TR-8000 Display Unit, Flush/Panel mount	102
14.4	AIS Antenna Splitter	Error! Bookmark not defined.
14.5	SANAV – GPS Marine Antenna.....	103
15	Abbreviations and Definitions	104
16	Service Procedure	108
16.1	Tron TR-8000 AIS Installation – registration form	109
16.2	Trouble Description Form	110
17	SERVICE AGENTS	111
18	List of Figures	112

1 Revision History

Revision no.	By	Date	Page(s)	Versions	Reason for change
9	MOLM	13.06.14	56,80	Version reference: TR8000 OP_IN MAN-v9	Alarm relay fixup.
10	MOLM	15.10.14	28,84	Version reference: TR8000 OP_IN MAN-v10	Changes due to certification against IEC61993-2ed2.
11	MOLM	12.05.16		Version reference: TR8000 OP_IN MAN-v11	Changes in shipList, Removed combination antenna, general cleanup. New alarm symbol (IEC-62288 Ed2)

2 Software revisions

The TR-8000 is delivered with SW version according to table below which is filled in by either Jotron, our Distributor, Dealer or Installation company. When SW update is done according to instructions in Jotron TB 01-2012 (Technical Bulletin), an additional line of information will be filled in to reflect the latest change. There will be no need for retraining after SW upgrade is performed.

The sub menu that shows SW versions can be found selecting:

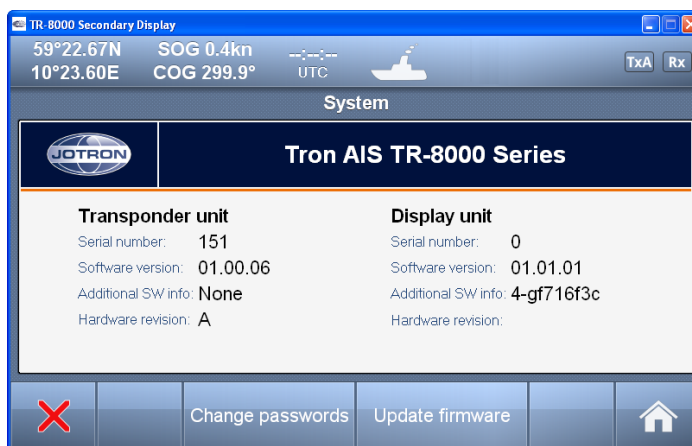
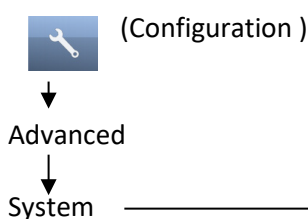

Transponder unit	Display unit	By	Date	Change
01.01.03	01.01.05	Jotron	12.05.2016	IEC-61992-2 ed 2 IEC-62288 ed.2 2014

Later revisions can be found in “Tron AIS TR-8000 Quick Reference Guide”, paragraph: “ **3 Software Revisions**”

3 Introduction

3.1 Safety Instructions

- This equipment should be installed according to the instructions found in the installation part of this manual.
- The equipment should not be mounted in a way that exposes it for excessive heat from the sun or other sources.
- The equipment should not be mounted in a flammable environment.
- The equipment should not be mounted in a way that exposes it to direct rain or water.

CAUTION!

This equipment contains CMOS integrated circuits. Observe handling precautions to avoid static discharges which may damage these devices.



- Do not open equipment. Only qualified personell should service the equipment.

3.2 Compass Safe Distance

Transponder unit:

Standard Compass: 95cm

Steering compass: 65cm

Display unit:

Standard Compass: 30cm

Steering compass : 14cm

3.3 Copyright Notice

This manual, as well as the software described in it, is furnished under license and may be used or copied only in accordance with the terms of such license. The content of this manual is furnished for informational use only, is subject to change without notice, and should not be constructed as a commitment by Jotron AS. Except as permitted by such license, no part of this publication may be reproduced, stored in a retrieval system, or transmitted, in any form or by any means, electronic, mechanical, recording, or otherwise, without the prior written permission by Jotron AS.

Please remember that existing artwork or images that you want to include in your project may be protected under copyright law. The unauthorized incorporation of such material into your new work could be a violation of the rights of the copyright owner. Please be sure to obtain any permission required from the copyright owner.

3.4 Disclaimer Notice

The information in this book has been carefully checked and is believed to be accurate.

However, no responsibility is assumed for inaccuracies.

Jotron AS reserves the right to make changes without further notice to any products or modules described herein to improve reliability, function or design.

Jotron AS does not assume any liability arising out of the application or use of the described product

3.5 Disposal Instructions

The TR-8000 Transponder and Display shall be disposed according to local regulations regarding Electronic Waste Recycling in the country the equipment is taken ashore.

At time of writing this manual (2012), there are some common regulations which allies:

Europe:

Directive 2002/96/EC (WEEE) Waste Electrical and Equipment Directive

Equipment is labeled with this symbol:



USA:

Most states have implemented some kind of recycling act, but there is not yet a federal law about this issue.

Elsewhere:

Follow local regulations regarding disposal of electronic equipment

3.6 Software and Hardware revisions

See chapter 1 & 2

3.7 Ingress protection

Transponder unit:

- IP56
- IPx6
- IEC 60945, Exposed

Display unit:

- IP54
- IEC 60945, Protected

4 Operation general introduction

Thank you for purchasing this Jotron AIS Class A transceiver.

The Jotron TR-8000 has been developed to offer you the highest level of performance and durability and we hope that it will provide many years of reliable service. This product has been designed to meet the highest possible quality standards and should you encounter any problems with this product, please contact your local dealer who will be pleased to offer any assistance.

4.1 About AIS in general

The system is based on the IMO regulation for AIS using Self Organized Time Division Multiple Access (SOTDMA) technology based on a VHF Data Link (VDL).

- The system operates in the following modes:
 - Autonomous (continuous operation in all areas)
 - Assigned (data transmission interval remotely controlled by authority in traffic monitoring service)
 - Polled (in response to interrogation from a ship or authority)
 - Silent (listening only, use with caution)
- The system is synchronized with GPS time (UTC) to avoid conflict among multiple users. If GPS data is not available, the system is self synchronized using the VDL.
- The VHF channels 2087 and 2088 are the main AIS channels in addition to local AIS frequencies.
- AIS transponders onboard ships exchange various data as specified by IMO and ITU on either frequency set up by :
 - The frequency management telecommand (DSC)
 - Special AIS messages sent from a AIS Base station.
 - Manual input of special region
- The normal transmit power is 12.5W, but under certain conditions, as during tanker loading (according to ISGOTT regulation), or the use of regional settings, a low power option (1W) is automatically selected.

5 Equipment List

5.1 Standard Supply

85500 TR-8000 AIS Class A :

Stock No.	Name	Type	Qty.
85300	TR-8000 Transponder Unit		1
85400	TR-8000 Display Unit		1
85041	Mounting bracket, Display unit		1
85042	Locking ring, mounting bracket		2
85720	Curled knob, mounting bracket		2
86853	GPS Antenna, std	SANAV SA-200	1
86854	GPS Antenna stainless stand		1
86145	Cable, 5m Patch RJ45 waterproof		1
86848	Operator and Installation Manual		1
86581	Power cable, TR-8000 Display unit		1
87666	Screwdriver to unlock terminals		1

5.2 Optional Supply

Stock No.	Name	Type
82484	VHF Antenna	Procom CXL 2-1LW/h
81768	Jotron Signal Splitter	
86870	Pilot cable for TR-8000 display	Jotron
80665	AC/DC Power 100-240 VAC/ 24V DC	Jotron
92375	240V AC cable, Europe (for 80665)	Jotron
97521	AC Power cable, UK. (for 80665)	Jotron
81986	AC Power cable, USA (for 80665)	Jotron
80138	Plug kit for 81768	Jotron

6 TR-8000 Description

The Tron AIS TR-8000 consists of two separate units interconnected by Ethernet. The Transponder is the main unit, handling the basic AIS functionality, including sensors and RF functions, while the Display unit is used for setup and display of the AIS data.

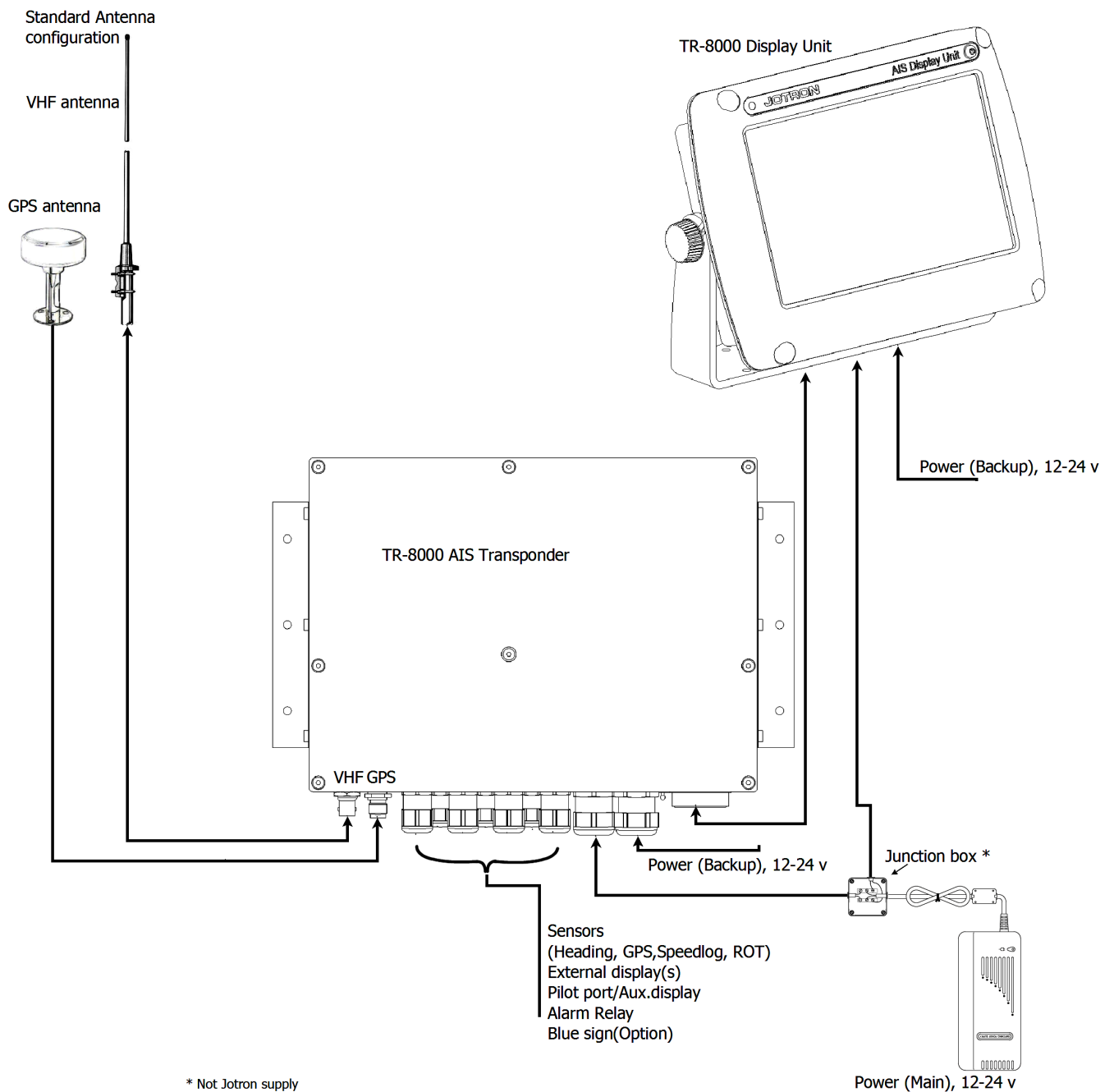

6.1 Functionality

The main features are:

Safety of navigation by automatically exchanging navigational data between ships (Class A transponders), coast stations, Class B transponders and receiving positional data from AIS-SARTs (Search and Rescue beacons) and AtoNs (Aids to Navigation).



- Class A AIS transmitter and receiver (transponder)
- Class B compatible (receives all Class B messages)
- Short safety related messages and other short messages.
- 7" color LCD panel with LED backlight connects to transponder unit using Ethernet.
- Interfaces for AIS compatible radar, ECDIS/ECS/Chart plotter and/or PC selectable through RS422 (IEC 61162-2), RS232 or Ethernet (UDP).
- GPS and VHF antenna for easy installation available.
- Built-in GPS receiver for time synchronization and backup position.
- SD-Card slot for future upgrades.

The information exchanged between ships using AIS transponders are:

Static data:

- MMSI (Maritime Mobile Service Identity).
- IMO number (where available).
- Call sign and name.
- Length and beam.
- Type of ship.
- Location of position-fixing antenna on the ship.

Dynamic data:

- Ships position with accuracy indication and integrity status.
- UTC.
- Course over ground (COG).
- Speed over ground (SOG).
- Heading.
- Navigation status (manual input).
- Rate of turn (where available).

Voyage related data:

- Ships draught.
- Hazardous cargo (type).
- Destination and ETA (at masters discretion).

6.2 Transponder Unit

The Transponder Unit contains all the core functionality of the AIS system and can function as a separate unit connected to other display solutions confirming with the AIS message format. It consists of a splash proof Alumina casing with the following connection possibilities:

- VHF antenna and GPS antenna
- Display connector (Ethernet)
- External display connections (“Ecdis Port” and “Pilot/Aux Port”).
- Sensor connections
- DGNSS/DGPS
- Beacon receiver connection
- Alarm relay

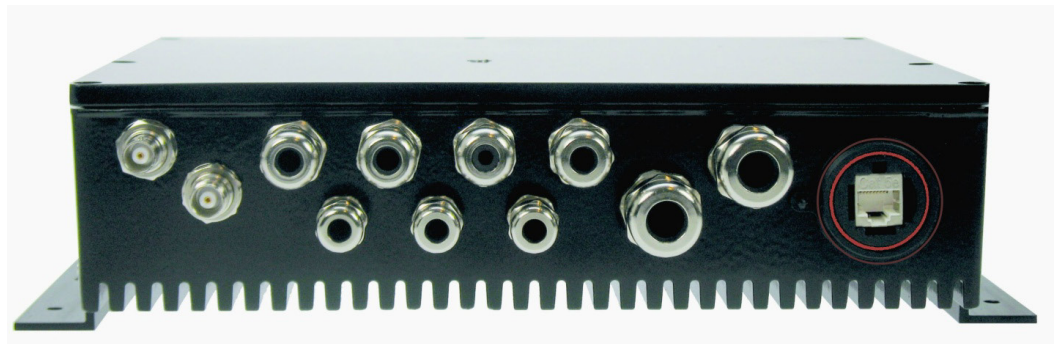

Front View



Side View

Complies with the environmental requirements specified in IEC 60945 Ed.4 Exposed, and is certified for IP56 /IPX6. The operating temperature is from -25°C to +55°C and storage temperature from -30°C to +70°C

The receiving section of the Transponder consists of three VHF receiver circuits, for continuous reception on both AIS channels (configurable from 154MHz-164MHz) and the DSC channel (ch70). The transmitter circuitry is connected to the same antenna terminal and is switched internally.

Functionality for direct reporting with satellites (Long-range AIS broadcast) is implemented and operates when so configured by the competent authorities.

The internal power supply of the Transponder is galvanically isolated in order to protect the internal circuitry and operates in a wide voltage input range from 10.8V – 31.2V. A backup power source can be connected if available. Automatically switching to backup power source will take place if the main source of power is lost.

6.2.1 LED Indicators:

- Transmission
- Reception
- Alarm
- Status



6.2.2 Main functionality:

- Transmit and receive AIS data packets over the VHF link
- Receive DSC messages
- Provide time and position data from internal GPS
- Receive and handle data from external sensors.
- Provide information about own and other ships positions to the display units, both the TR-8000 Display unit, and to high speed ports like “External Display” and “Pilot/Aux Display”.

6.2.3 VHF Antenna Connector

This is a BNC type antenna connector to be connected directly to an external VHF antenna or antenna splitter to receive and transmit VHF frequencies.

For more information see section **8.2.2**

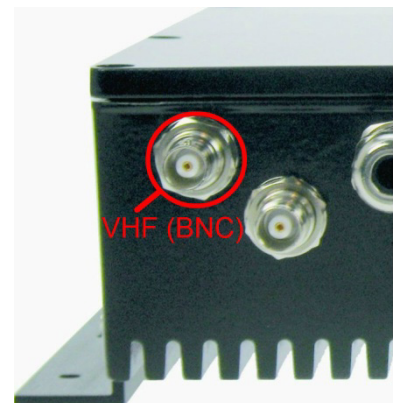

6.2.4 GPS Antenna Connector

This is a TNC type antenna connector to be connected directly to an external GPS antenna or antenna splitter to receive GPS information.

For more information see section **8.2.1**

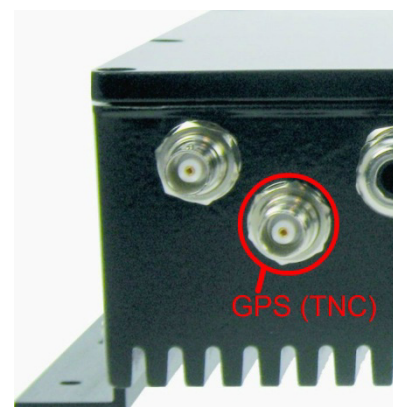

6.2.5 External Display (Ethernet) Connector

RJ45 type waterproof Ethernet connection

For more information see section **8.3.1.5**



6.2.6 Multipurpose Cable Glands

The Transponder Unit is fitted with up to 9 multipurpose cable glands for waterproof, shielded connection with the unit. There are 3 different sizes in order for the best possible fit for different cable types. All wiring should be



drawn in shielded cables connected to the chassis of the Transponder by the cable glands.

The multipurpose connection glands are provided as in .

Max Quantity	Min Cable Outer Ø [mm]	Max Cable Outer Ø [mm]	Minimum Ø above braiding [mm]	Recommended use
3	3.5	7	2	Sensors
4	4.5	9	4	Communication
2	7	12.5	5	Power

Table 1: Quantity and specification of multipurpose cable glands.

6.3 Display Unit



Front View

The Display unit is the user interface for the AIS system on the bridge. It is used to configure the TR-8000 system and to present AIS data about own and other ships, both graphically and in list form. The Display Unit consists of a splash proof housing with a 7 inch LCD colour display with touch screen. Splash proof connections for Main and Backup power, Pilot plug and Transponder (Ethernet) are present on the back side of the unit. The internal power supply is switched in order to obtain a high efficiency over the whole voltage input range from 10.8V – 31.2V. A Backup power source can be connected if available. This will be automatically switched in if the main source of power is lost.



Rear View

The main features of the Tron AIS Display Unit are:

- Give the user information about other ships with AIS in the vicinity.
- Enable the user to obtain information about other ships and send and receive safety messages to other ships with AIS Transponders.

- CPA/TCPA
 - Enable the user to configure the AIS System.
 - Alert the user about alarms from the AIS system.
 - Pilot Port connection directly to the Display Unit.
- Certified to IP54 and IEC 60945 Ed.4 "Protected".

Operating temperature from -25°C to +55°C and storage temperature from -30°C to +70°C

7 Operational description

The operational description chapter assumes that the TR-8000 Ais Transponder is fully installed using the instructions found in the Installation chapter.

7.1 On/Off button

ON/OFF button handles 3 different options

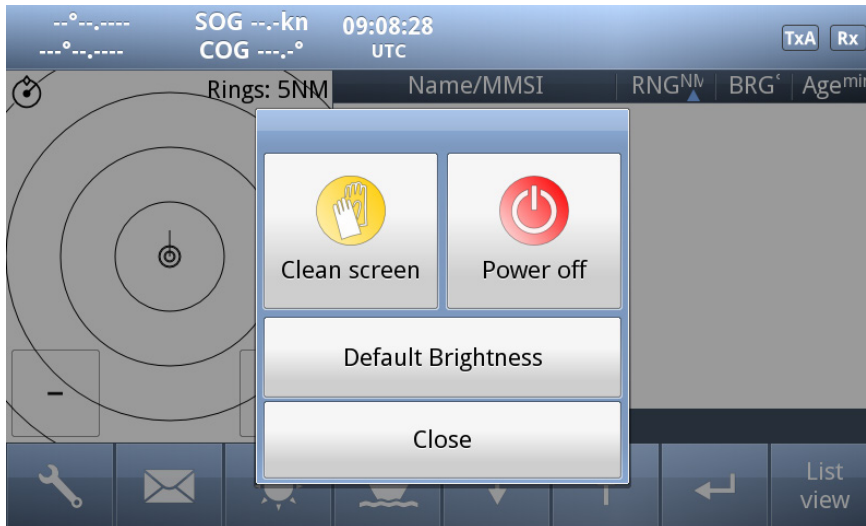

When ON/OFF is pushed, a popup menu is displayed with some display Options. Additionally, if the brightness is low, it will automatically be increased. This feature can be used if the user by some reason has too low visibility to adjust the brightness the regular way. If the Default Brightness button is pressed, the brightness will be set to a 50% value. Otherwise the current brightness level will be restored when the dialog is closed.

7.1.1 Clean Screen

Clean Screen is a function which turns off all touch sensitivity, enabling the user to clean the screen without pushing buttons unintentionally.

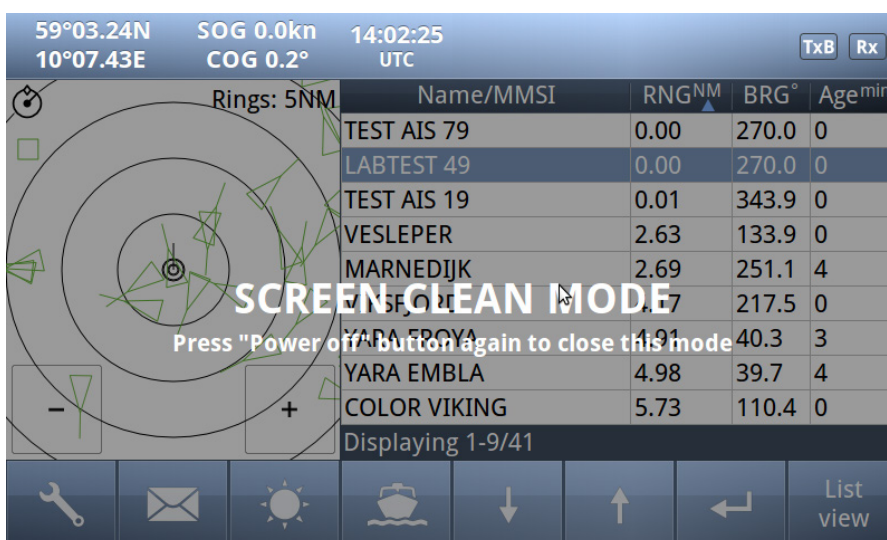

7.1.2 Power off Display

If the **Power off Display** is selected, only the Display Unit is turned OFF and the AIS functionality of the Transponder will still be active. Note that the ship list will need some time to recover when turning the Display unit on again. This is dependent on when the messages from the different vessels are received. The message logs for sent and received messages will also be lost.

Note that the Transponder unit will issue an alarm when the display is shut down, and there may be no means to acknowledge this alarm if the display is turned off!

7.2 Display Unit menu system.

The screenshot shows the main window of the Display Unit menu system. It is divided into three main sections:

- Status Bar:** Located at the top, displaying coordinates (59°03.25N, 10°07.41E), speed (SOG 0.0kn), heading (COG 233.5°), and time (11:46:03 UTC). It also includes TxB and Rx buttons.
- Content Section:** The central area, split into a radar display on the left and a table of vessel data on the right. The radar display shows concentric rings (8NM) and various vessel tracks. The table lists vessel names, MMSI numbers, ranges, bearings, and ages.
- Button Bar:** Located at the bottom, containing icons for settings, messages, sun, vessel, zoom in, zoom out, and a list view button.

Name/MMSI	RNG ^{NM}	BRG [°]	Age ^{min}
M/S BOHUS	5.38	36.5	0
SOUTHERN ACTOR	5.44	37.0	0
LOS 112	10.28	80.5	0
257137700	12.43	268.6	2
SIVA	12.49	201.5	2
HELENE	14.48	214.7	0
SD191 SILVERON	15.61	170.3	0
STANGHOLM	16.28	131.2	0
DANAVIK	16.39	117.1	0

Displaying 7-15/33

The main window contains three main sections.

7.2.1 Status Bar

The Status Bar is shown in a close-up view, highlighting its components:

- Dynamic navigational data (Position, Speed, Heading etc.):** Displays coordinates (59°03.25N, 10°07.44E), speed (SOG 0.0kn), heading (COG 274.8°), and time (14:03:54 UTC).
- Clock:** Displays the time (14:03:54 UTC).
- Other informative icons (Tx,Rx, Nav status, Alarms etc.):** Includes TxB and Rx buttons.

The **Status bar** is visible in all the sub menus.

7.2.2 Content Section

Displays the current selected window and the corresponding data
 Example below shows **Main View**:

Main View is a combination of **Graphical** and **List** view:

Name/MMSI	RNG ^{NM}	BRG [°]	Age ^{min}
M/S BOHUS	5.38	36.5	0
SOUTHERN ACTOR	5.44	37.0	0
LOS 112	10.28	80.5	0
257137700	12.43	268.6	2
SIVA	12.49	201.5	2
HELENE	14.48	214.7	0
SD191 SILVERON	15.61	170.3	0
STANGHOLM	16.28	131.2	0
DANAVIK	16.39	117.1	0

Displaying 7-15/33

All menus, menu buttons and settings are displayed in this section.

7.2.3 Button Bar

Contains all the functional buttons for above window:

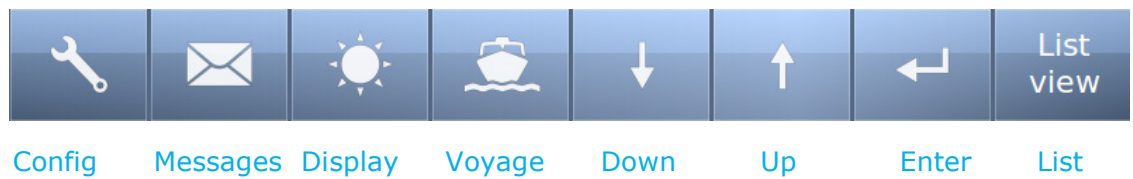

The functionality of the buttons on the **Button Bar** is dependent on the content of the **Content Section**.

7.2.4 Important Buttons shown in different Views:



Return to last menu **without saving**.



Confirm, save data and return to last menu.
If the Icon is not highlighted, indicates no data has changed



The **Home button** will take you to **Main view** without saving.



Enter – Show detailed information (“Page 1”) on selected item



Will be shown when vessel is selected with **Enter** button and will show “Page 2” of information about vessel

SPEED/SAN	SOG	TKG	TKG	TKG	TKG	TKG
10°07.45E	COG	WT	WT	WT	WT	WT
SUPERSPEED 2		Name/MMST	SMGM	BRG	Age	
Call sign	IMO	TEST AIS 79	0.00	270.0	0	
MMSI	258092000	TEST AIS 19	0.00	270.0	0	
IMO	2.66NM	IMO: 252.5°	2.62	133.8	0	
COG	0.0kn	COG: 120.0°	2.70	252.8	0	
TKG	0°00.0N	TKG: 263°	4.17	217.5	1	
TKG	10°02.51E	TKG: 45N	4.17	217.7	0	
TKG		TKG: ASKERBAERENGEN	4.92	40.4	0	
TKG		TKG: YARA PROVA	4.98	39.7	2	
TKG		TKG: YARA EMBLA	5.37	38.4	0	
TKG		TKG: COLOR VIKING				



When “Page 2” of Vessel information is shown, this button can be used to switch back to “Page 1”



Arrow Down –Select next item on a list



Arrow Up –Select previous item on a list



Arrow Right – Select item to the right



Arrow Left – Select item to the left



Configuration – of Own ship, Display, Regions, Alarms, Indicators and Advanced



Messages – See **Received** and **Sent** messages, **Reply** to received and send **New**



Display setting – Adjust **Brightness** or select **Day/Night** mode



Voyage settings – Nav. Status, Destination, ETA, Draught, Cargo, Persons aboard

Some of the functions cannot be altered without entering a password. There are two levels of passwords, a user password and an administrator password. The default passwords are “OP” and “SE”.

7.2.5 Indicating ICONS



Receive data on either of the two AIS channels. If **Inactive**, shown as



Transmit on either channel A or B shown as **TxA** or **TxB**. Icon shown is **Inactive**. **Active** is shown with Green color as the Rx icon above.

Alarm Status:



No alarms



Unacknowledged Alarm caused by one or more incidents from Table 3



Unacknowledged Alarm caused by one or more incidents from Table 3

Navigation Status:



Under way using Engine



At Anchor



Not Under Command



Restricted Manoeuvrability



Constrained by her draught



Moored



Aground



Fishing



Sailing

Transmission Modes :



Silent Mode - Transmission is turned OFF



Normal transmission mode (12.5W)



Low Power (1 W) if

- Vessel type = "Tanker" and
- speed is below 3 knots and
- Navigation Status = "Moored"

7.2.6 Ship List

List view

The display unit receives data about all the ships with an active AIS transmitter in the area and presents this data in a list in the main window. The list displays the name or MMSI, range to own ship, bearing and age of presented data.

59°03.25N 10°07.44E		SOG ---kn COG ---.°		14:04:42 UTC				TxB Rx	
Name/MMSI	RNG ^{NM}	BRG°	SOG ^{kn}	COG°	Age ^{min}				
TEST AIS 79	0.00	219.9	0.0	---	0				
TEST AIS 19	0.01	320.6	0.2	96.0	0				
VESLEPER	2.62	133.9	0.0	338.0	0				
COLOR VIKING	3.90	87.8	15.7	352.5	0				
ASKERBAERINGEN	4.17	217.7	0.0	177.6	0				
VIKSFJORD	4.17	217.5	0.0	275.6	1				
YARA FROYA	4.91	40.3	0.0	184.0	4				
YARA EMBLA	4.98	39.7	0.1	272.5	1				
257137700	12.21	267.2	7.9	325.2	3				

Displaying 1-9/32

Graphical view

When the graphical view is off, course and speed are also displayed.

The list can be sorted on any of these criteria, but an AIS SART will always be presented at the top of the list. If the list is scrolled down, or other sorting criteria than “range in ascending order” is selected, the display will revert to a “range in ascending order” sorted list after approx. 3 minutes of user inactivity.

The columns “Name/MMSI”, “RNG”, “BRG” and “Age” are always present, but “SOG” and “COG” may be replaced by “CPA” and “TCPA” or added in addition (See paragraph 10.2.3)

Example of all listed:

59°03.25N 10°07.43E		SOG ---kn COG ---.°		09:51:04 UTC				TxB Rx	
Name/MMSI	RNG ^{NM}	BRG°	SOG ^{kn}	COG°	CPA ^{NM}	TCPA ^{min}	Age ^{min}		
LOS 112	10.39	79.9	7.3	5.0	10.2	0:06:07	0		
LOS 110	10.82	248.4	9.7	77.7	4.9	-1:19:01	0		
CSL BERGEN	10.97	248.4	10.0	61.0	9.5	2:56:17	0		
WILSON ROUGH	11.55	266.4	10.6	289.4	1.6	1:18:09	0		
259622000	13.20	269.4	0.0	236.3	---	---	0		
BROVIG BORA	14.01	270.2	8.5	285.0	5.1	-1:02:18	8		
CYGNUS	14.30	227.0	3.8	359.8	7.1	2:00:54	0		
GLOBAL MOON	15.60	93.2	1.4	309.6	13.7	-1:33:21	0		
M/T BROVIG WIND	16.52	114.5	4.7	43.0	15.8	-0:25:00	0		

Displaying 12-20/26

Graphical view

Note that in areas with heavy traffic, the number of received Vessels can be large. In cases where more than 200 vessels are received, the display unit will at any time display the 200 nearest vessels. Display of other types of objects (base stations atons etc.) will not be restricted in any way. This restriction also affects the graphical view described in the next section. The output to external devices (ECDIS,Pilot) is not affected by this filtering.

7.2.6.1 Column description

- **Name/MMSI :**
Shows the MMSI (**Maritime Mobile Service Identity**) of the ship until its Name is received. Name is transmitted more seldom than MMSI numbers
- **RNG^{NM}:**
Is the Range to the Vessel in Nautical Miles (NM)
- **BRG[°]:**
Bearing to the Vessel in degrees from your position
- **SOG^{kn} :**
Speed Over Ground in Knots
- **COG[°]:**
Course Over Ground in degrees
- **CPA^{NM}:**
Closest Point of Approach : An estimated point in which the distance between you and the other vessel are at its minimum value
- **TCPA^{min}:**
Time To Closest Point of Approach : The time (in Minutes) until you reach the **CPA**
- **Age^{min}:**
Shows how many minutes since last reception from this vessel

7.2.7 Graphical View

Graphical
view

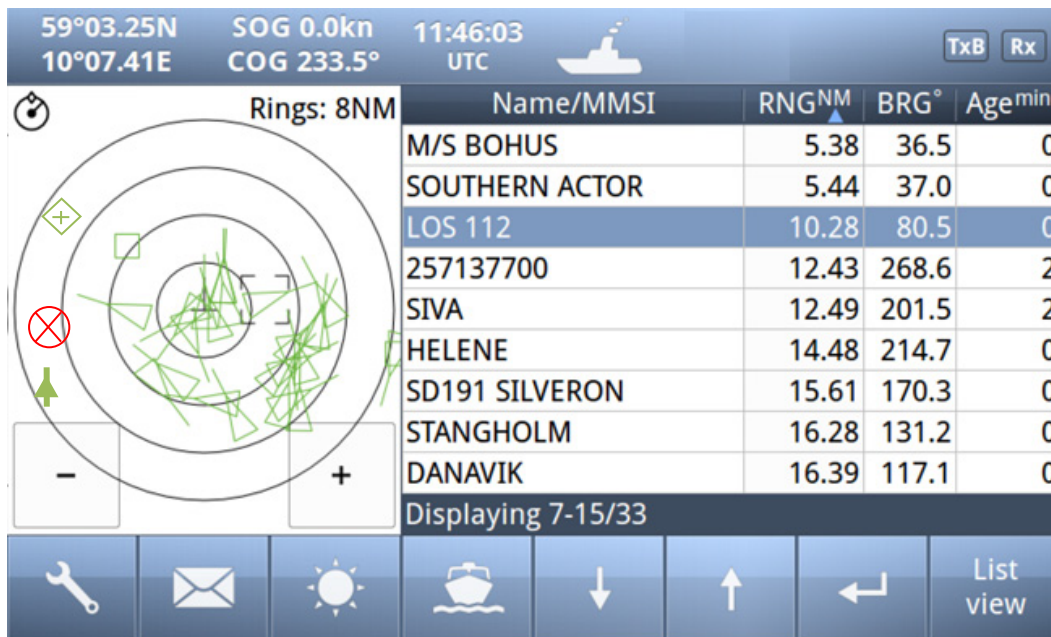

The *graphical display* of the ship list plots the positions of other AIS targets relative to your own position in a frame on the left side.







A vessel with neither a reported heading nor COG will be oriented toward the top of display area. The restriction of number of vessels described in the above Ship list section, also apply to the graphic display.

The user may switch between North Up and Head Up, but if no heading or COG is available, or if the ship is anchored/moored, the North Up configuration will automatically be chosen. If a valid heading is received from external heading sensor (Gyro, Satellite compass or similar), own ship will be oriented according to this. If heading is lost, Course Over Ground (COG) will be second choice for own ships orientation on the display.

The setup is done in the *Display Settings* menu. In this menu, it is also possible to toggle between Graphical and List view as default.

In the display menu, the user can choose not to return to the graphical view when exiting menus.

Different types of targets are displayed with different icons.

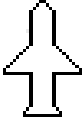
	<p>Active Vessel If the CPA/TCPA system is activated, ships on collision course are displayed with a red color and double thickness of the lines. Own ship is indicated in the same way as other ships, but is always in center.</p>
	<p>Sleeping target Smaller symbol than “Active Vessel” without a beam line Sleeping targets are defined based on either:</p> <ul style="list-style-type: none"> • Range more than X Nautical miles • Class B <p>Activation can be either of the definitions above and can be visible or not</p>
	<p>AIS base station</p>
	<p>Physical Aton An Aids to navigation buoy indicating that it is off position is indicated with a red color.</p>
	<p>Virtual Aton A symbol provided from typically a base station, to indicate fixed objects important to navigation.</p>
	<p>AIS SART. Will be displayed with a red color. AIS TEST will be displayed with normal color.</p>
	<p>SAR Aircraft</p>

7.3 Voyage Settings

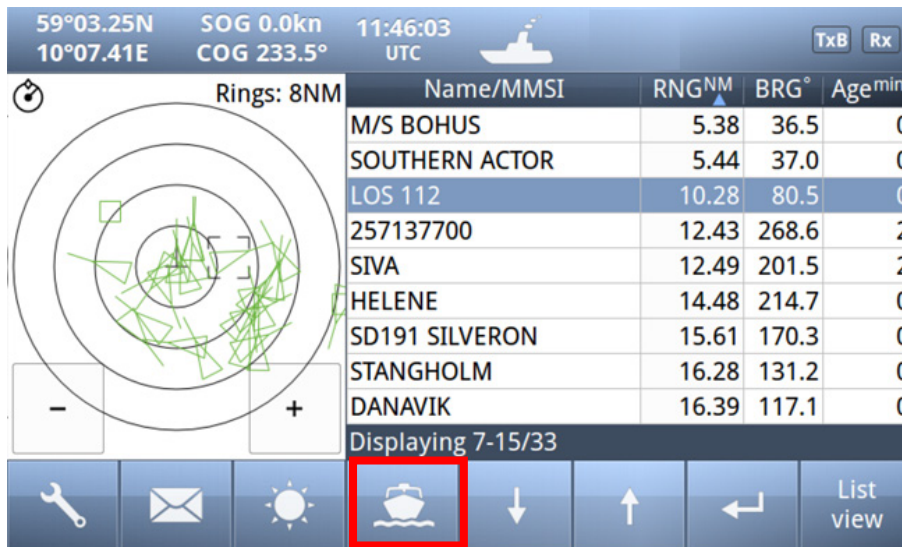

Red square shows button selected to get to this menu

The **Voyage Settings** contains all the information to be entered or changed for a voyage. This information will be available for other AIS stations, both vessels and base stations, so it is important to keep these parameters up to date.

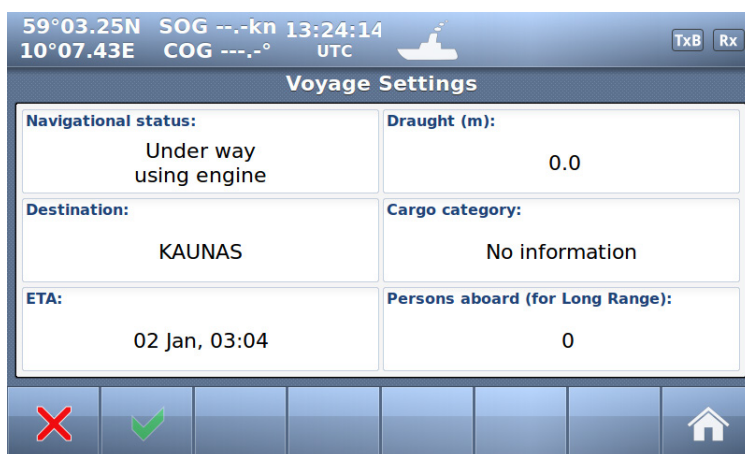

You may use one of these buttons:

- Navigational Status
- Destination
- ETA (Estimated Time of Arrival)
- Draught
- Cargo Category
- Persons Aboard

to set correct information for the Voyage

7.3.1 Navigational Status

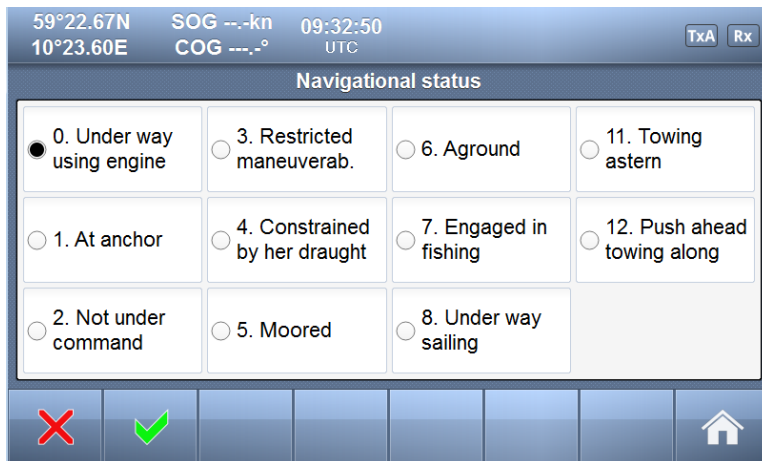

The options available for the navigational status are as follows:

- Under way using engine,
- At anchor,
- Not under command ¹,
- Restricted manoeuvrability ²,
- Constrained by her draught ³,
- Moored,
- Aground,
- Engaged in fishing ⁴
- Under way sailing ⁵
- Not Defined (Default) ⁶

- Power driven vessel towing astern (regional use)
- Power-driven vessel pushing ahead or towing astern (regional use)

¹**Vessel not under command** means a vessel which through some exceptional circumstance is unable to maneuver as required by these Rules and is therefore unable to keep out of the way of another vessel.

²**Vessel restricted in her ability to manoeuvre** means a vessel which from the nature of her work is restricted in her ability to manoeuvre as required by these Rules and is therefore unable to keep out of the way of another vessel. The term “vessels restricted in their ability to manoeuvre” shall include but not be limited to:

- A vessel engaged in laying, servicing or picking up a navigation mark, submarine cable or pipeline;
- A vessel engaged in dredging, surveying or underwater operations;
- A vessel engaged in replenishment or transferring persons, provisions or cargo while underway;
- A vessel engaged in the launching or recovery of aircraft;
- A vessel engaged in mine clearance operations;
- A vessel engaged in a towing operation such as severely restricts the towing vessel and her tow in their ability to deviate from their course.

³**Vessel constrained by her draught** means a power-driven vessel which, because of her draught in relation to the available depth and width of navigable water, is severely restricted in her ability to deviate from the course she is following.

⁴**Engaged in fishing** means any vessel fishing with nets, lines, trawls or other fishing apparatus which restrict manoeuvrability, but does not include a vessel fishing with trolling lines or other fishing apparatus which do not restrict manoeuvrability.

⁵**Under ways sailing** means any vessel under sail provided that propelling machinery, if fitted, is not being used.

⁶**Not Defined (Default)** is used when TR-8000 is delivered from factory. Then none of above selections are made

7.3.2 Destination

The destination of the voyage is to be entered here using a maximum of 20 characters.

NOTE!

Many countries require destination input is according to **GUIDANCE ON THE USE OF THE UN/LOCODE IN THE DESTINATION FIELD IN AIS MESSAGES** from [IMO SN/Circ.244](#)

Text from the Guidance:



Recommended use of the UN/LOCODE

6. The recommended format is to indicate the port of departure at the first six positions of the data field followed by a separator and then the code for the next port of call.
7. In order to identify that it is a LOCODE, to separate the locations and to indicate the 'from' and 'to' ports, a '>' symbol should be used as a separator. See example below.

A ship is leaving Dubai bound for Rotterdam. Use of the UN/LOCODE would represent this voyage as below:

"AE DXB>NL RTM"

8. If the next port of call is unknown, "?? ???" should be entered instead of the UN/LOCODE in the corresponding place in the data field. See example below:

"AE DXB>?? ???"

9. If the port of departure does not have a designated UN/LOCODE then "XX XXX" should be entered instead of the UN/LOCODE in the corresponding place in the data field. See example below:

"XX XXX>US PBI"

10. If the next port of call does not have a designated UN/LOCODE the commonly accepted English name of the destination port should be entered, preceded by "===" (3 "equals signs"). If no such name is known, the locally used name should be entered. In this case, there may not be enough space available to indicate the port of departure. See example below:

"===Orrviken"

11. If only the general area of destination is known the name or accepted abbreviation of the area preceded by "===" ("three equals signs") should be entered. See example below:

"NL RMT> === US WC"

Indicating a destination on the United States West Coast.

7.3.3 ETA

The Estimated Time of Arrival is displayed to other AIS units and should be updated if the expected arrival time is changed.

59°03.25N SOG ---kn 13:18:33
10°07.44E COG ---° UTC

Arrival date and time

Month: 01 day: 02 time: 03:04

1 2 3
4 5 6
7 8 9 0

✗ ✓ ← → 🏠

7.3.4 Persons Aboard (optional)

This parameter indicates the number of persons aboard the ship at the given moment.

This parameter is not sent to other ships or base stations, only through the Long Range Port which is normally not used (in 2011)

59°03.25N SOG ---kn 13:23:32
10°07.44E COG ---° UTC

No of Persons

0

1 2 3
4 5 6
7 8 9 0

✗ ✓ ← → 🏠

7.3.5 Cargo Category

Identifies Hazardous cargo, depending on the ship class. See chapter 10.1.1.1 <Type of Vessel> for reference.

59°03.24N SOG ---kn 13:22:39
10°07.43E COG ---° UTC

Cargo category

No information
 Hazard or pollutant cat X
 Hazard or pollutant cat Y
 Hazard or pollutant cat Z
 Hazard or pollutant cat OS

✗ ✓ ← → 🏠

7.3.6 Draught

The Draught parameter specifies the maximum depth of the ship in meters and decimeters.



7.4 Messages

WARNING!

Use of AIS text messages between ships must not be used to avoid collisions when time is critical. AIS systems are not required to have an audible alarm to indicate the arrival of all text messages.

The use of AIS text messaging does not relieve the vessel of other requirements, such as the Vessel Bridge-to-Bridge Radiotelephone regulations or of the requirements to sound whistle signals and display lights or shapes in accordance with the International or Inland Navigation Rules.

Usage During Emergencies - With respect to using AIS safety related text messages in emergency situations, users must be aware that they may not be received, recognized or acted upon as Global Maritime Distress Safety Systems (GMDSS) messages would be by the Coast Guard, other competent authorities or maritime first responders. Thus AIS must not be relied upon as the primary means for broadcasting distress or urgent communications, nor used in lieu of GMDSS such as Digital Selective Calling radios which are designed to process distress messaging. Nonetheless, AIS remains an effective means to augment GMDSS and provides the added benefit of being 'seen' (on radar or chart displays), in addition to being 'heard' (via text messaging) by other AIS users within VHF radio range (Ref: USCG Safety Alert 05-10).

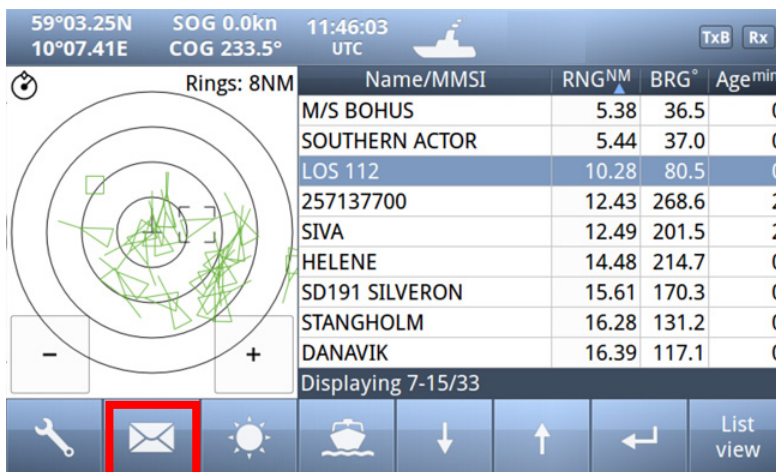

Red square shows  button selected to get to this menu

The messages icon opens the

7.4.1 Received messages

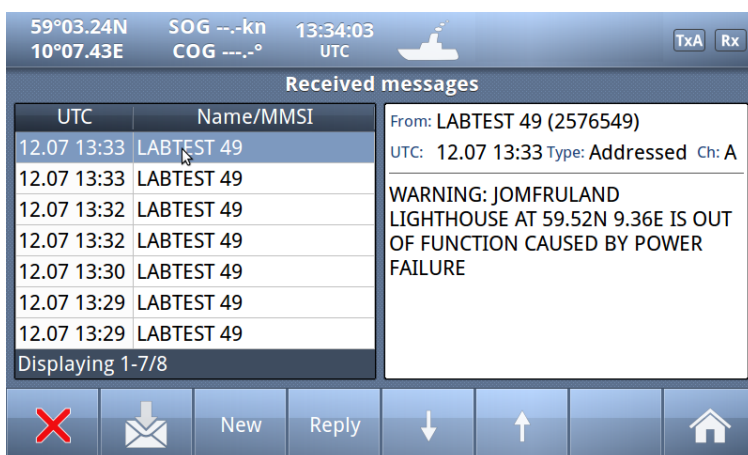

By pushing the buttons on the bottom bar, you can switch to:

- Sent messages
- Write New
- Reply
- Scroll up or down through

received messages

When you select one of the messages in the list, you will see the content in the right window

If you press the button, the display will swap to:



7.4.2 Popup when received message

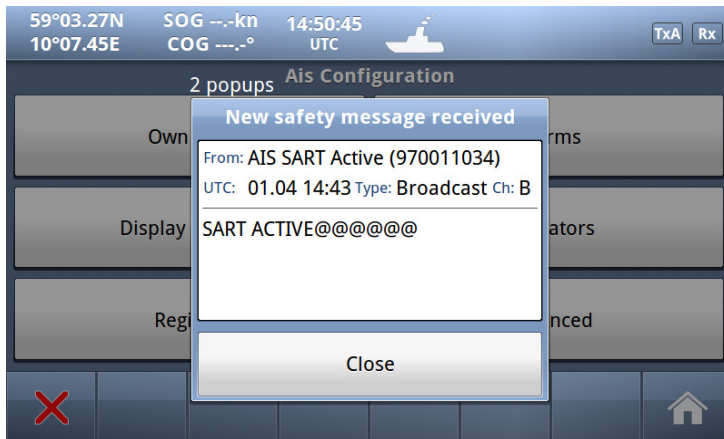

Example showing “Popup” of received “Safety message” from AIS SART

The message must be acknowledged by pressing “Close” button

7.4.3 Sent messages

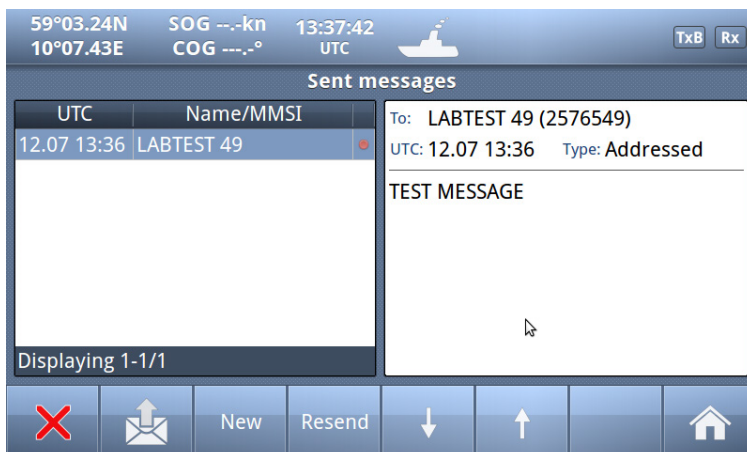

By pushing the buttons on the bottom bar, you can switch to:

- Received messages
- Write New
- Resend
- Scroll up or down through sent messages

When you select one of the messages in the list, you will see the content in the right window

There is also a “Status” field on each line showing:



Message SENT OK



Message transmission in PROGRESS



Message transmission FAILED

7.4.4 Write New message



Be advised, all messages in this context are SAFETY RELATED and should not be used for other purposes.

For this reason, this functionality is protected by a user password.

Default Password = OP

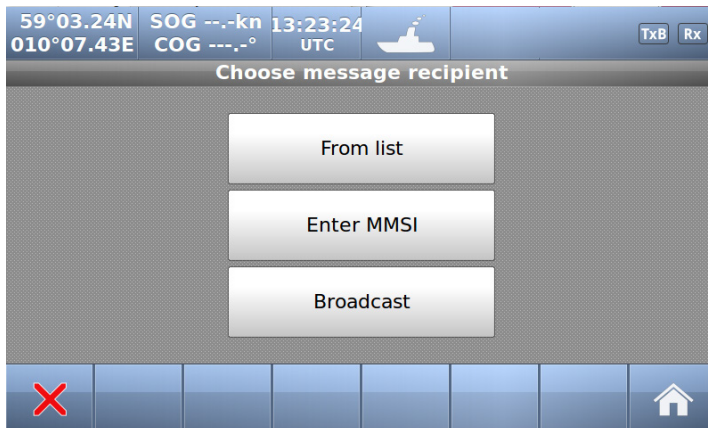

Select here message recipients:

- From list (Of received ships)
- Enter MMSI (directly)
- Broadcast (to all)

7.4.4.1 Message recipients "From list"

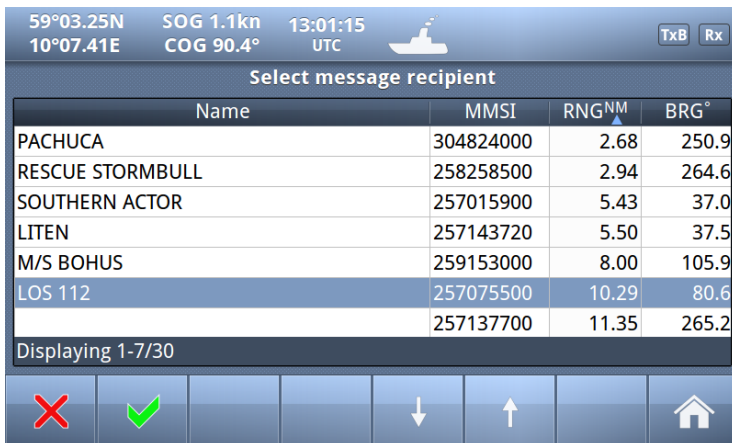

Select

1. Which ship
2. Confirm with 

Then a new window opens:

7.4.4.1.1 Write text





When a target is selected, the keyboard window opens, and allows the user to write a message. The total allowed length is 156 characters.

Confirm with 

Which opens the

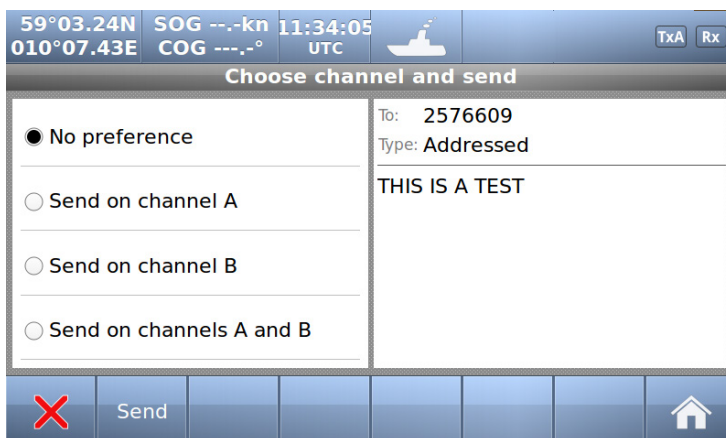
7.4.4.1.2 Choose channels and SEND



- Select preference
- Send : 

7.4.4.2 Message recipients "Enter MMSI"

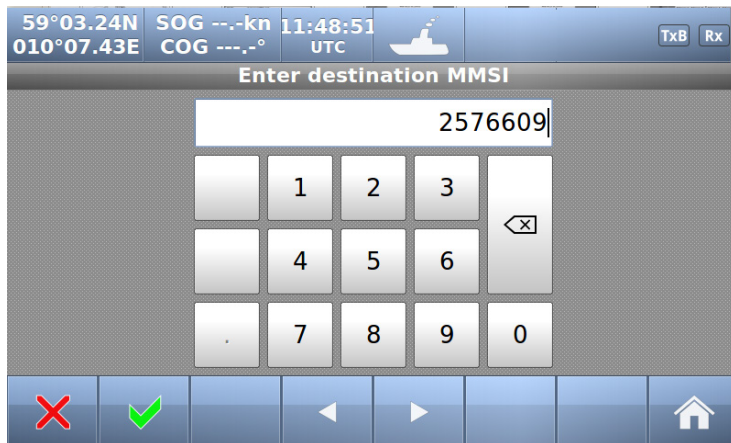

1. Enter MMSI
2. Confirm with 
3. Write Text (as described above)
4. Select Channel and Send (-""-)

7.4.4.3 Message recipients "Broadcast"

1. Write Text (as described above)
2. Select Channel and Send

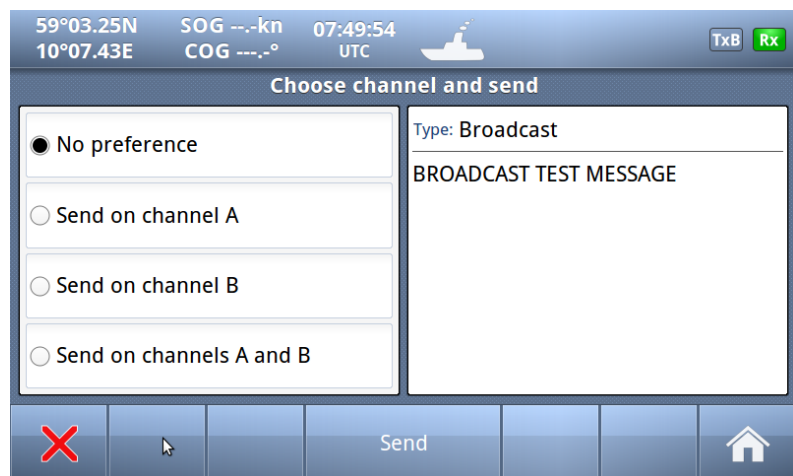

7.5 Display Settings

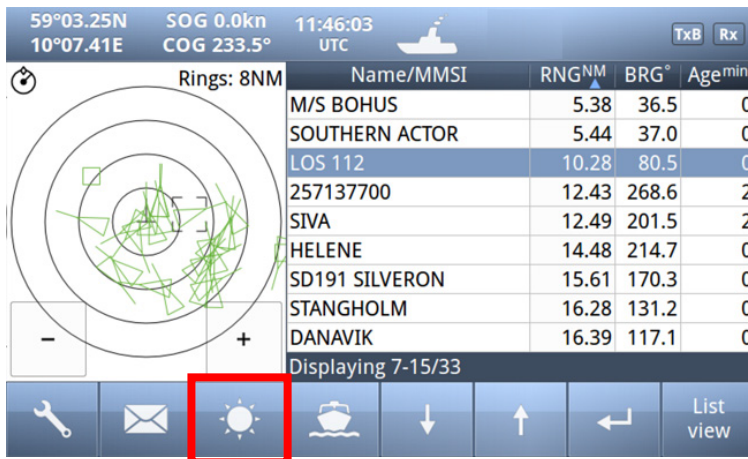

Red square shows button selected to obtain to this menu

In the **Display settings** menu, you can adjust Brightness level and switch between night and day mode. Each mode has its own brightness level.

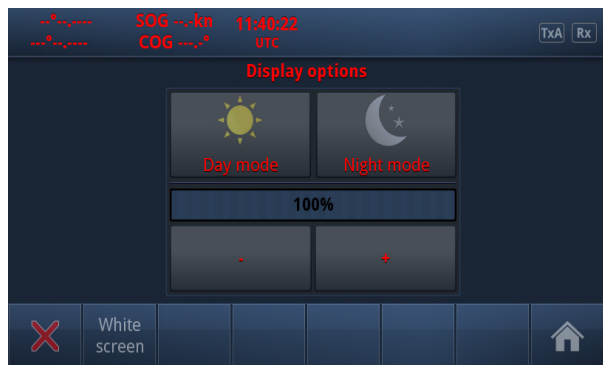
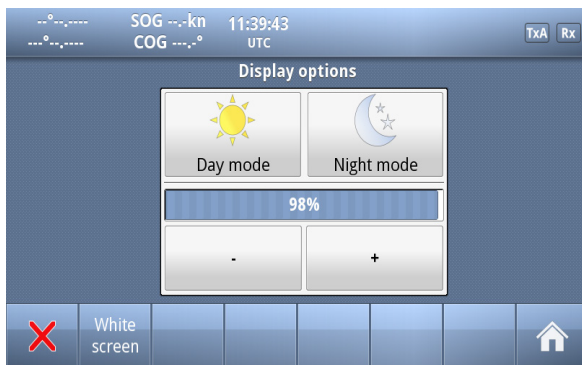

In the low brightness end of the scale, the steps are more accurate to adapt to very low intensity levels.

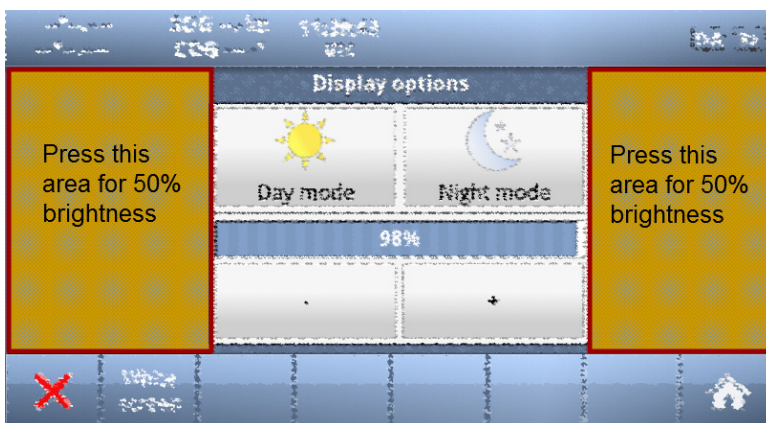

Touching the empty area at the left or right side of the display restores a 50% brightness level if the display gets too dark to see the actual buttons for this purpose.

Restoring of 50% brightness level is also accessible by pressing the on/off button (see chapter 7.1)

Press "Home"  to return to Main Window again

8 Installation

8.1 Mechanical Mounting

8.1.1 Transponder unit

Use the standard Mounting Kit. For dimensions and positioning of holes see *Figure 14-1 TR-8000 Transponder Unit- mechanical dimensions*

When selecting a mounting location for the Transponder the following guidelines apply:

1. Keep the transponder out of direct sunlight.
2. Do not mount the transponder where it can be directly exposed to seawater as corrosion then may appear and cause leakage.
3. The unit must not be mounted near exhaust pipes and vents.
4. Even though the transponder is a robust unit, it is advised that it should be mounted where shock and vibration are minimal.
5. Unit shall not be located near electromagnetic field generating equipment
6. Leave sufficient space at the sides and top of the unit for maintenance and repair.
Also leave slack in cables for the same reason.
7. Do not mount transponder unit too close to a magnetic compass :

Compass safe distance:	Standard Compass:	95cm
	Steering Compass:	65cm

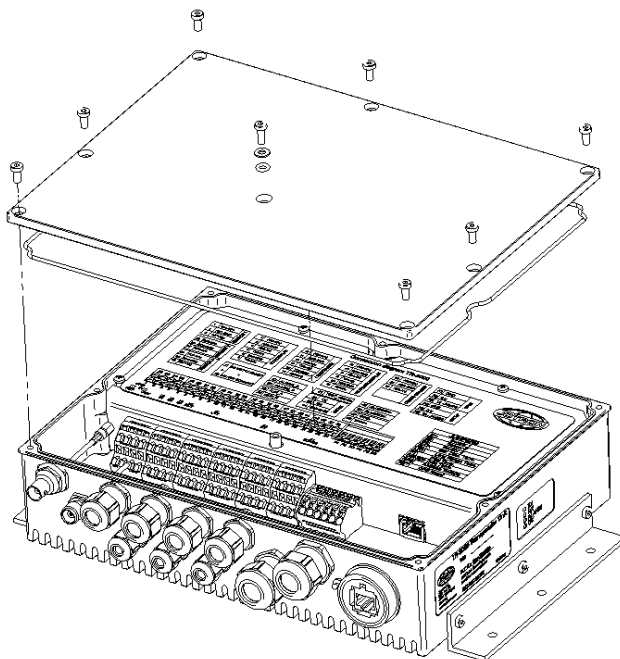

The TR-8000 transponder unit can be mounted in all directions, either on a wall, roof or floor. The unit is very robust and made of cast aluminum coated with black paint for best type of protection

For detailed mechanical drawings, see chapter 14, "Outline Drawings"

Figure 8-1 Transponder Unit, exploded view. Opening of outer Lid

8.1.2 Display Unit

The display unit can be installed as desktop mounted, roof mounted or flush mounted in a panel. Installation shall be near the conning position.

When selecting a mounting location for the Display Unit the following guidelines apply:

1. Do not mount the display unit where it can be directly exposed to seawater as corrosion then may appear and cause leakage.
2. The unit must not be mounted near exhaust pipes and vents.
3. Even though the transponder is a robust unit, it is advised that it should be mounted where shock and vibration are minimal.
4. Unit shall not be located near electromagnetic field generating equipment
5. Leave sufficient space at the back for connection to necessary cables.
6. Do not mount transponder unit too close to a magnetic compass :

Compass safe distance:	Standard Compass:	30cm
	Steering Compass:	14cm

8.1.2.1 Desktop Mounting

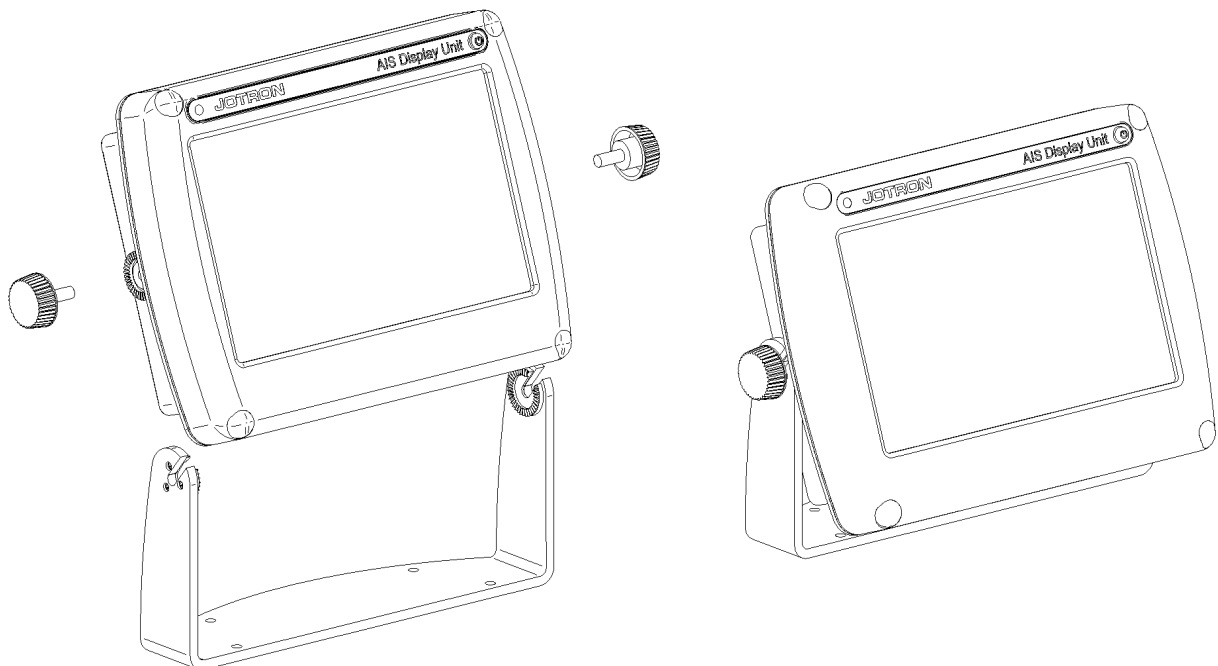
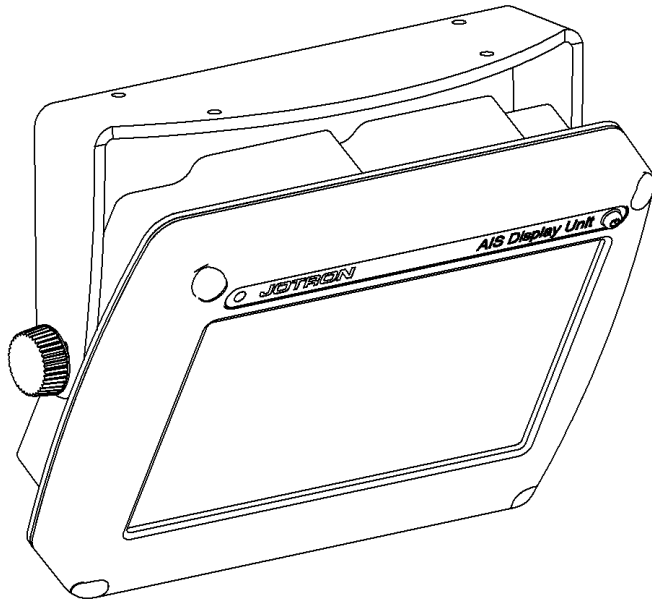

Figure 8-2 Desktop mounted Display Unit

For detailed mechanical drawings, see chapter 14,"Outline Drawings"

8.1.2.2 Roof Mounting



When display unit is mounted overhead/roof, it might be necessary to adjust Contrast/Brightness, see chapter **7.5 Display Settings**

Figure 8-3 Roof mounted Display Unit

For detailed mechanical drawings, see chapter **14 Outline Drawings**

8.1.2.3 Flush/ Panel Mounting

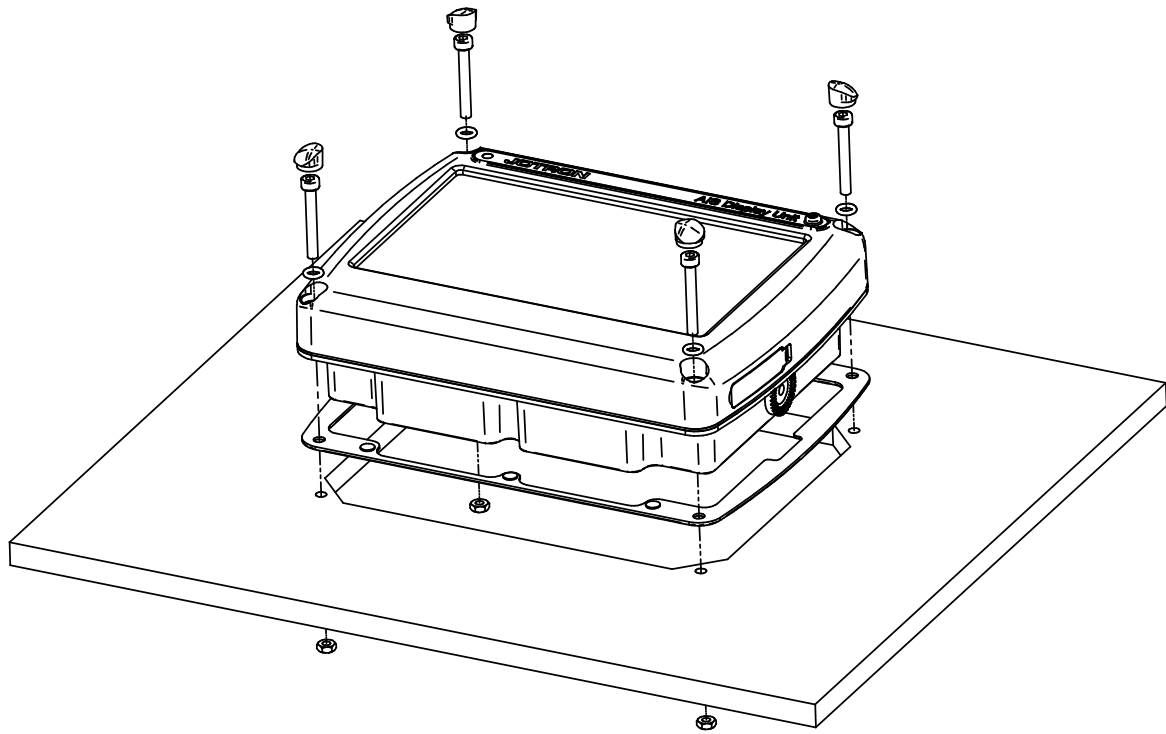

Figure 8-4 Flush mounted Display Unit, exploded view.

For detailed mechanical drawings, see chapter **14 Outline Drawings**

8.1.3 Antennas

As a general rule, longer horizontal distances to other antennas will minimize the interference and improve reception on all antennas.

Minimum distance is described in the figures below:

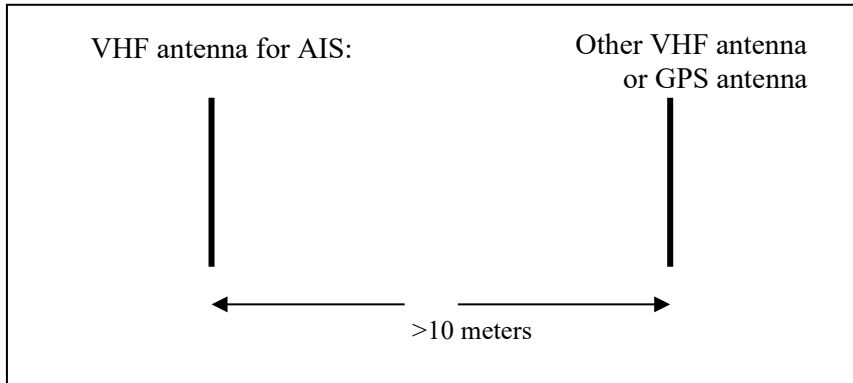

Figure 8-5 Horizontal separation distance.

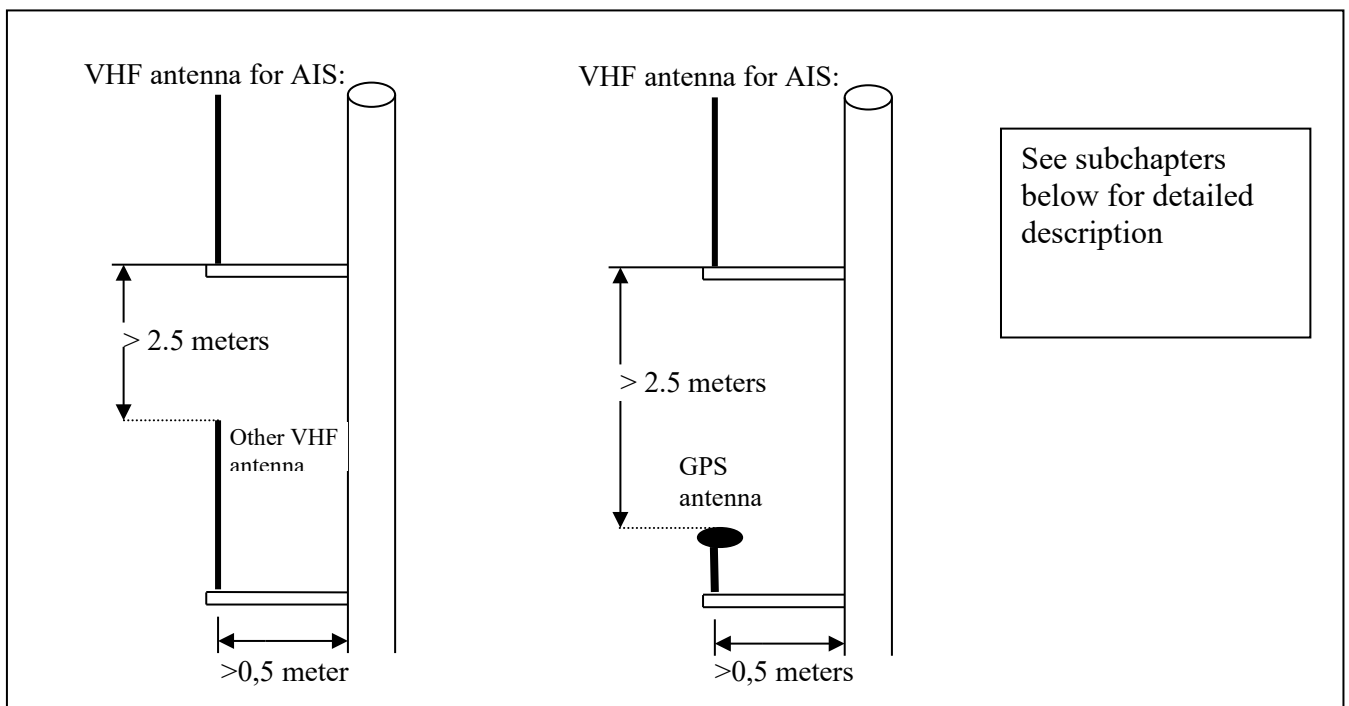

Figure 8-6 Vertical separation and distance from mast or other object of metal. For best isolation between antennas, place directly underneath with no horizontal separation.

8.1.3.1 GPS Antenna

When selecting a mounting location for the antenna, keep in mind the following points.

1. Select a location out of the radar beam. The radar beam will obstruct or prevent reception of the GPS satellite signal.
2. There should be no interfering object within the line-of-sight to the satellites. Objects within the line-of-sight to a satellite, for example a mast, may block reception or prolong acquisition time.
3. Mount the antenna unit as high as possible to keep it free of interfering objects and water spray, which can interrupt reception of GPS satellite signal if the water freezes.

8.1.3.1.1 Standalone type



TR-8000 is delivered as standard with a Sanav SA-200 GPS antenna with stainless steel stand and 15 meter cable with TNC connectors in both ends for direct connection between transponder and antenna.

The antenna can be mounted with three 6 mm bolts.

When Standalone GPS antenna is used, an additional VHF antenna must also be connected. For detailed description of this antenna, see Chapter 14 *Outline Drawings*

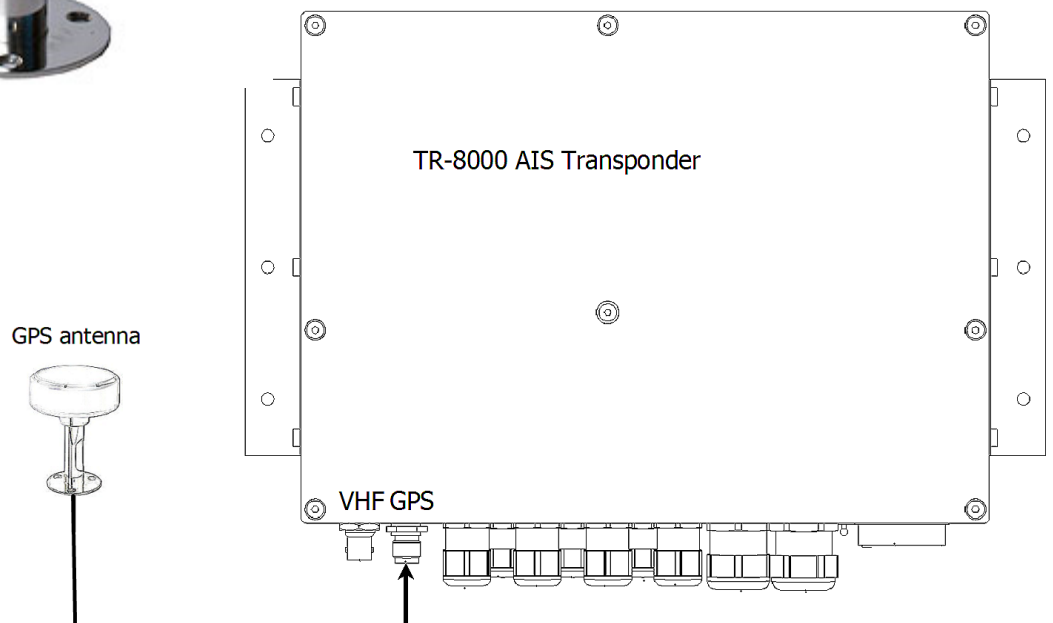

Calculation of cable length/attenuation etc is described in chapter

8.1.3.2 VHF Antenna



When individual GPS antenna is used, the additional VHF antenna must also be connected
For detailed description of this antenna, see Chapter 14 *Outline Drawings*

Location of the mandatory AIS VHF-antenna should be carefully considered. Digital communication is more sensitive than analogue/voice communication to interference created by reflections in obstructions like masts and booms. It may be necessary to relocate the VHF radiotelephone antenna to minimize interference effects. Install the VHF antenna referring to drawings in beginning of this chapter

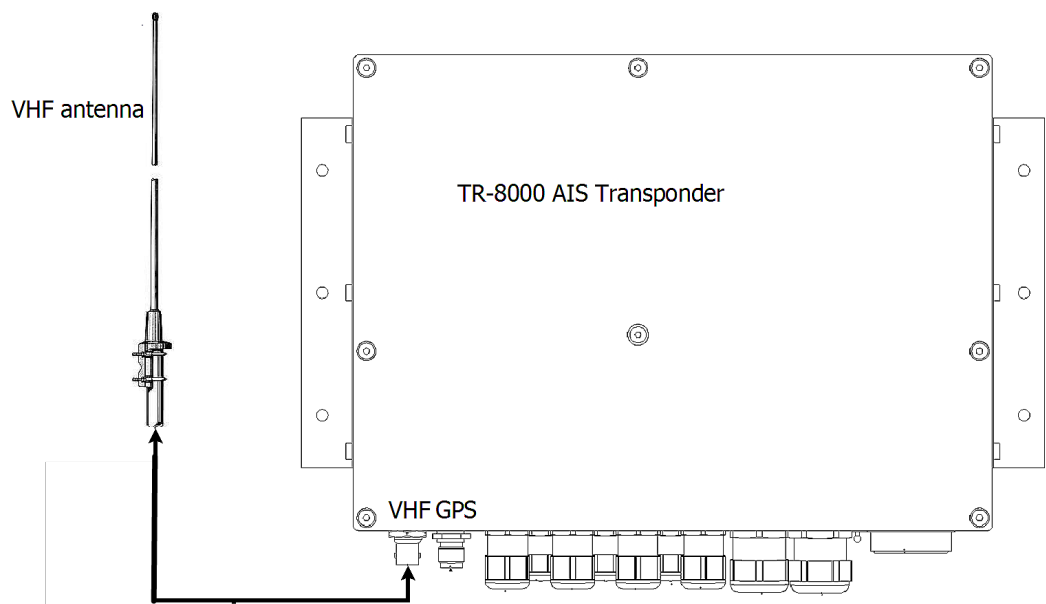

The antenna should be connected using RG214 cable or better using the connectors in the "Plug Kit" which is delivered with the units.

Calculation of cable length/attenuation etc is described in chapter **8.2**

8.2 Cabling

All outdoor installed connectors on coaxial cables should be fitted with preventive isolation such as vulcanizing tape to protect against water penetration into the antenna cable.

Coaxial cables should be installed in separate signal cable channels/tubes and at least 10 cm away from power supply cables. Crossing of cables should be done at right angles (90°). The minimum bend radius of the coaxial cable should be 5 times the cable's outer diameter.

The cables should be kept as short as possible to minimize signal attenuation.

The type of cables used onboard vessels should be:

- Halogen free
- Fire resistant or Flame retardant type
- Low smoke

8.2.1 GPS antenna

The table below gives recommendations on cables that can be used for the GPS antenna connections:

Type	Attenuation @1.5 GHz (dB/100m)	Remark
RG58	90	Default for use if length < 20 m and antenna = SANAV SA-200
RG214	35	Cable with lower loss
RG225	30	Cable with even lower loss

For optimum performance of the transponder approximately +10dB gain should be available when the cable attenuation has been subtracted from the GPS antenna preamplifier gain.

8.2.2 VHF antenna

The table below shows the attenuation on the VHF frequencies with different cable types:

Cable Type	Attenuation @150 MHz (dB/100m)	Diameter (mm)	Weight (kg/100m)
RG214	7	10,8	18,5
RG225	8	10,9	23,3

Example: A RG 214 cable with length of 40 meters will have an attenuation of 2,8 dB.

Please keep the cables as short as possible, and be aware that 3 dB losses mean only half the output power. If you have a transmitter delivering 12,5 W, and you have 3 dB losses in the cable, only 6,25 Watts will be at the antenna.

8.2.3 Cable between Transponder and Display Unit

The cable connecting the Transponder and the Display Unit has specially designed connectors on each end for waterproofing. The cable itself is a standard CAT-5 network cable

In order to ease wiring and installation, an optional cable is available with one end open, delivered with a small kit for post wiring assembly.

If the specified cable type is not used, the splash proofing of the unit is seriously degraded and the warranty is void if used in humid environment.



Figure 8-7 Connection cable for interconnection between the Transponder and the Display Unit

NOTE! If the units are mounted indoors in a warm dry environment without any need for water tightness, a standard CAT-5 or CAT-6 network cable may be used between the Transponder and the Display unit

8.3 Wiring and Connections

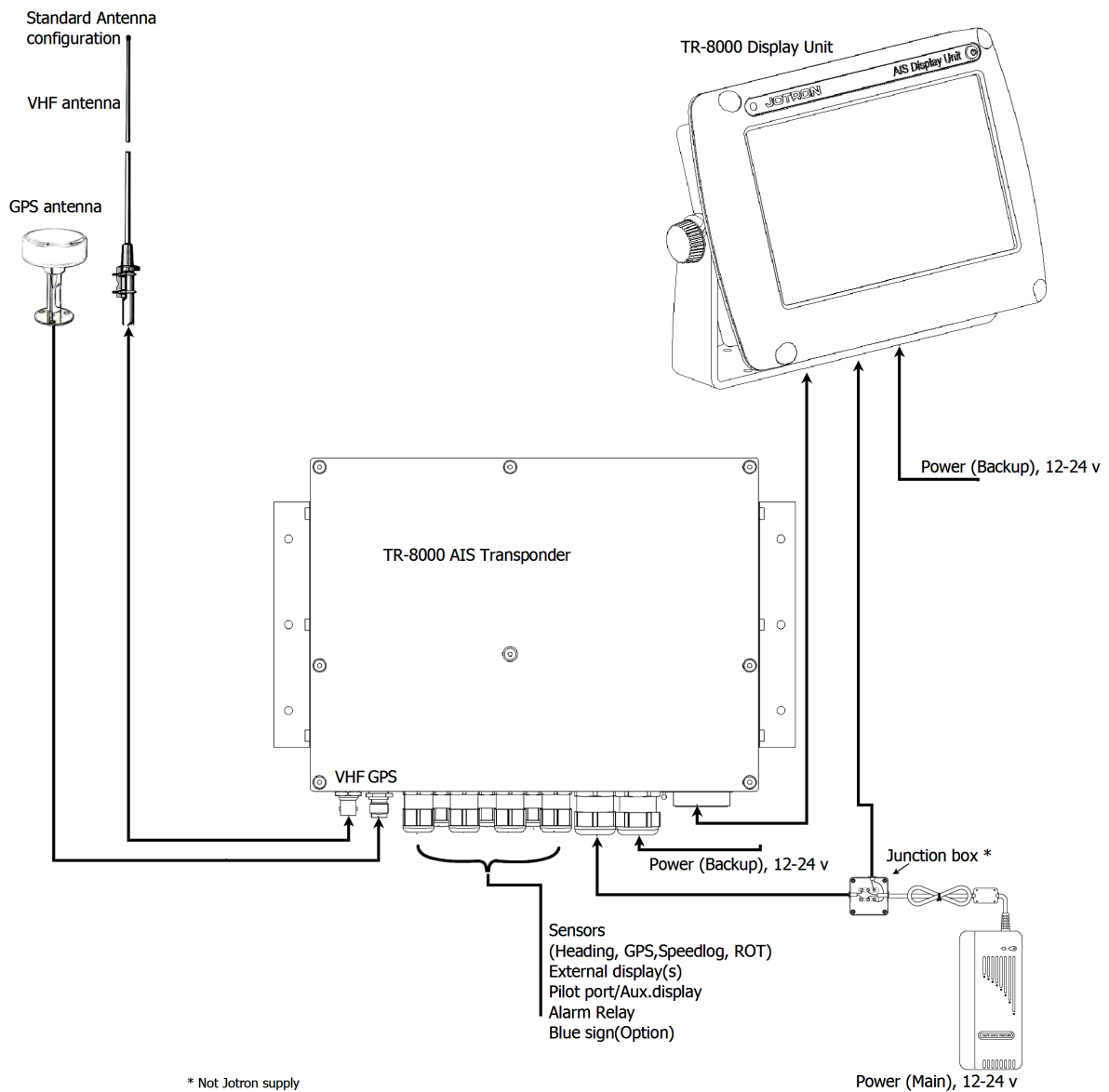

Figure 8-8 Block diagram of typical connections

Wiring and connection of Antennas (GPS + VHF) are described in chapter **8.1.3**

8.3.1 Transponder

In order to connect all sensors and external connections to the Transponder Unit, the lid must be removed by removing the screws on top of the unit. Pay attention to the seal gasket on the inside of the lid and the small o-ring positioned on the center screw. These gaskets need to be in place when mounted in order to keep the unit waterproof. When the lid is off, the connections to sensors, ECS etc can be made. The inner lid shall not be removed by user.

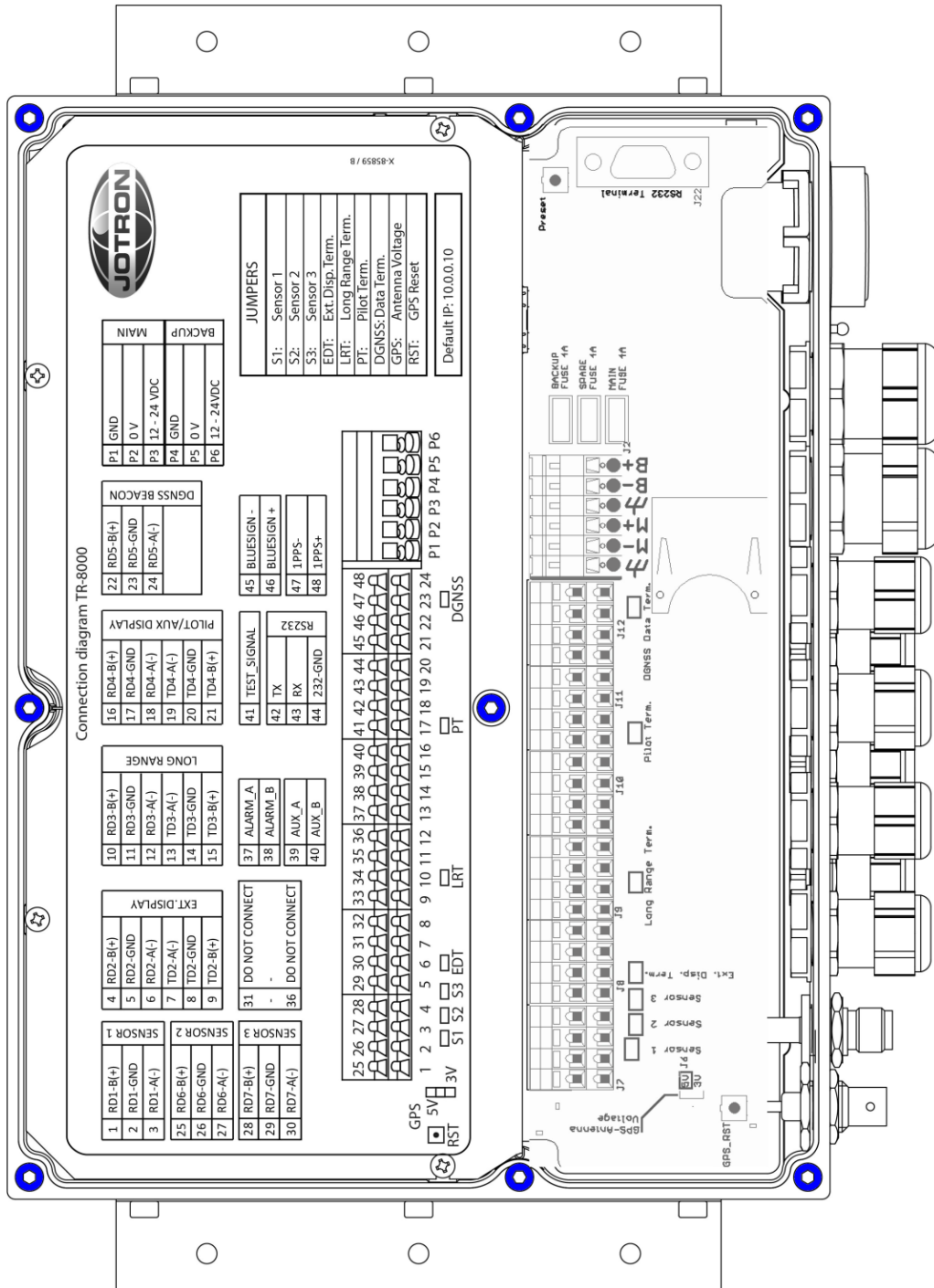

Figure 8-9 Transponder with lid removed, lid screws highlighted

8.3.1.1 Pictorial display of typical connections to the transponder

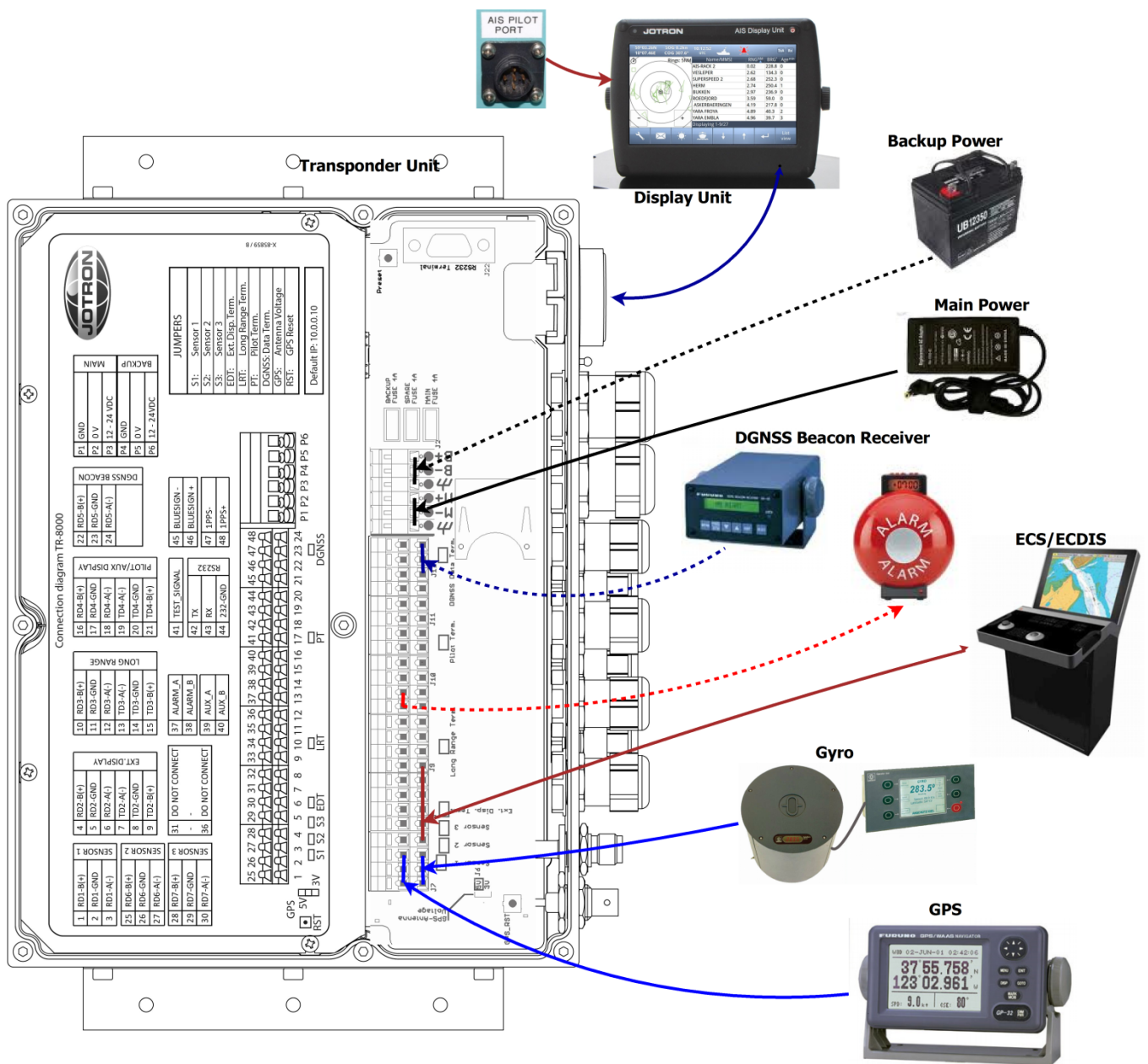

Figure 8-10: Typical connections to a TR-8000 transponder, dashed lines shows options

8.3.1.2 Label in transponder with connection tables

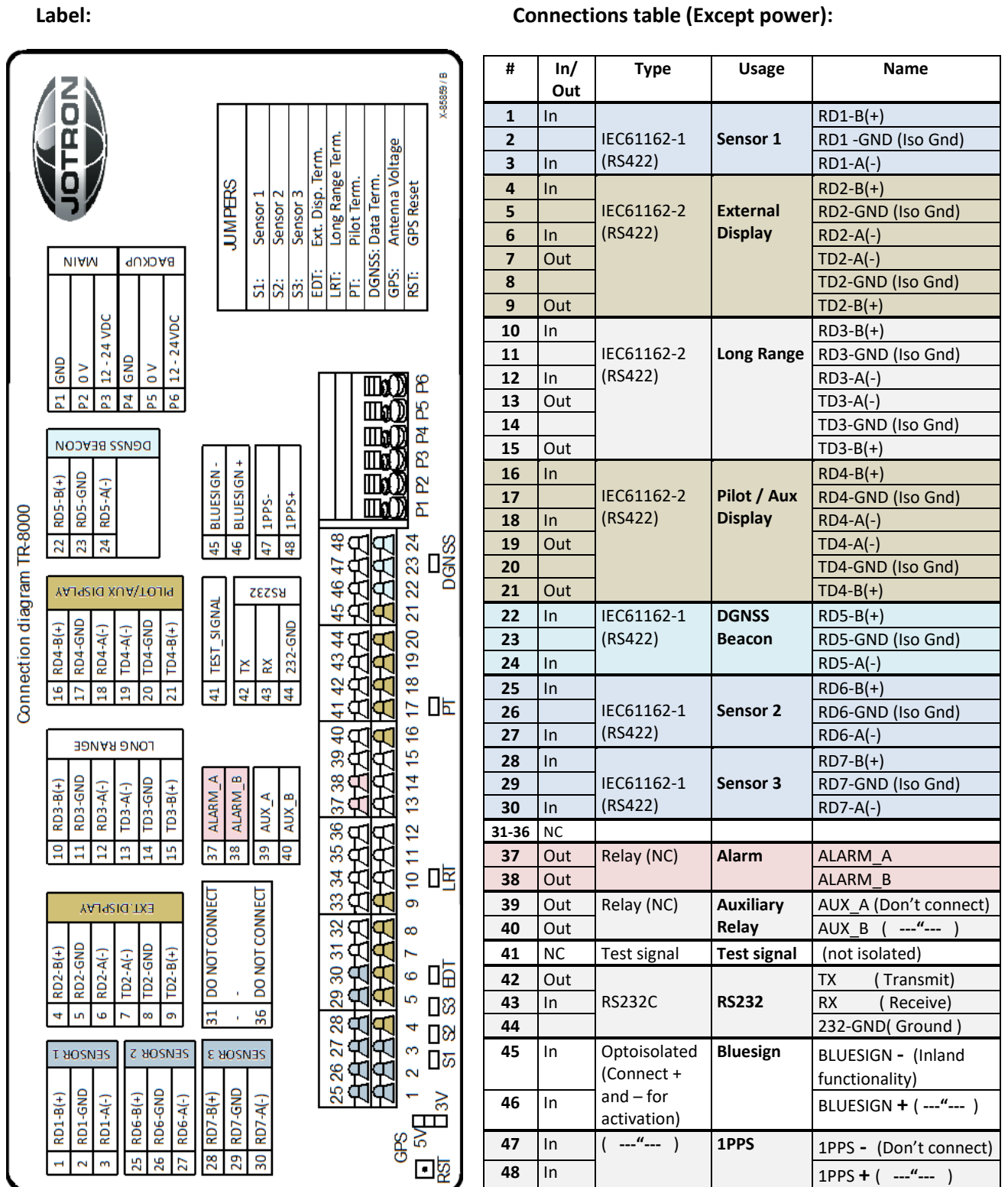

Figure 8-11: Label inside transponder with corresponding table showing details about each connection. It is coloured to differentiate sensors, display/pilot, alarm and DGNSS beacon interface

8.3.1.3 Power connection

Table showing connection of main and backup power

Connection	Function
P1	GND (Chassis)
P2	MAIN 0V
P3	MAIN 12 - 24 VDC
P4	GND (Chassis)
P5	BACKUP 0V
P6	BACKUP 12 - 24 VDC

See also figure Figure 8-10

Allowed voltage levels of the power supply to be connected with the transponder:

- Minimum = 10.8 volt
- Maximum = 31.2 volt

Recommended cable diameter: 2.5 – 4 mm²

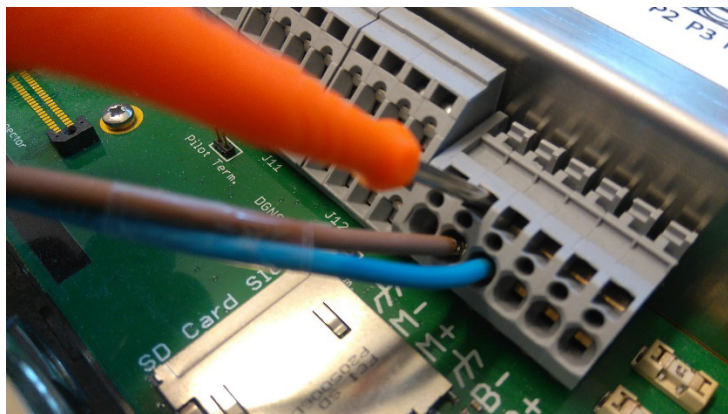

Figur 8-12 Use the supplied orange screwdriver to open the terminals.

8.3.1.4 Sensor connections

Sensors like GPS, Gyro, Speed log etc may be connected to the 3 different sensor inputs in the TR-8000 Transponder unit.

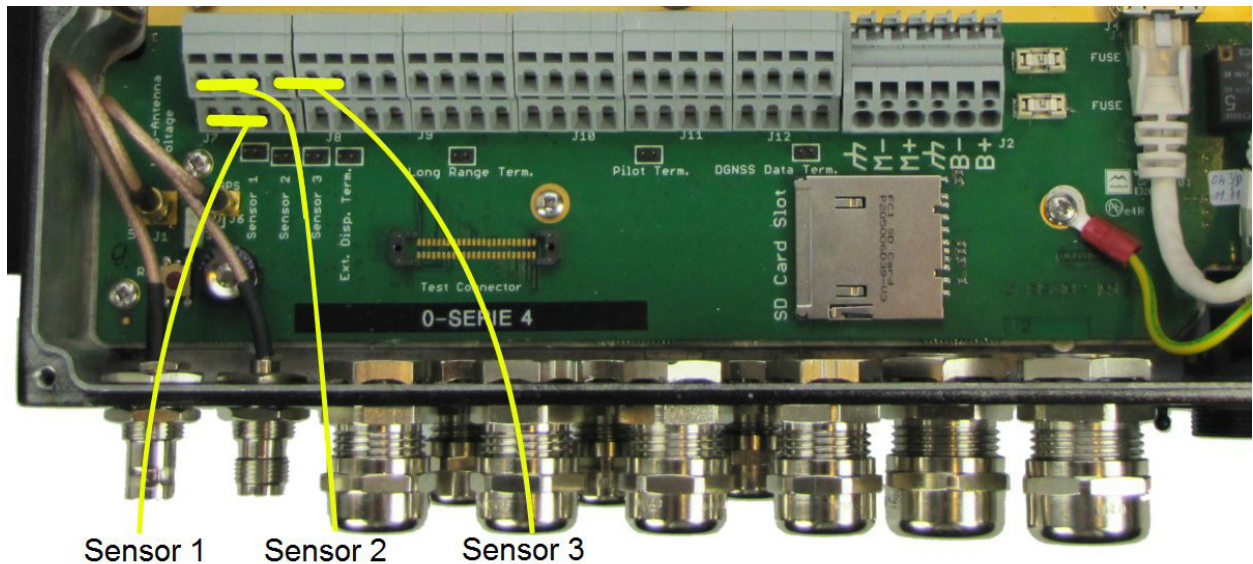

Recommended cable diameter: 0.25 - 2.5mm²

#	In/Out	Type	Usage	Name
1	In	IEC61162-1 (RS422)	Sensor 1	RD1-B(+)
2				RD1 -GND (Iso Gnd)
3	In			RD1-A(-)
25	In	IEC61162-1 (RS422)	Sensor 2	RD6-B(+)
26				RD6-GND (Iso Gnd)
27	In			RD6-A(-)
28	In	IEC61162-1 (RS422)	Sensor 3	RD7-B(+)
29				RD7-GND (Iso Gnd)
30	In			RD7-A(-)

The TR-8000 also offers a unique feature of troubleshooting sensor problems as it has a built in “Port monitor” which will display all raw sensor data in the Display Unit.

How to use this monitor, is described in chapter **10.2.1.6**

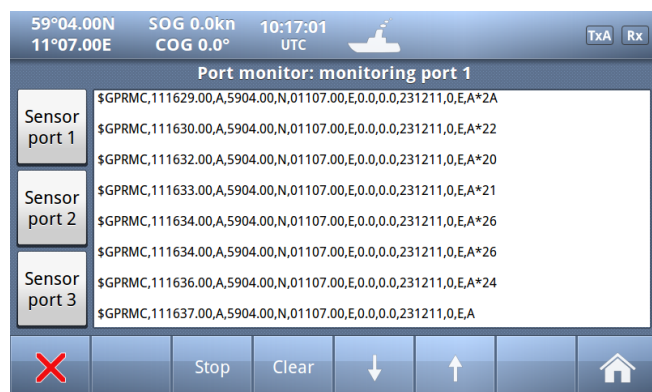

8.3.1.5 External display – ECDIS/Radar connections

The TR-8000 have a very flexible solution when it comes to connecting ECS/ECDIS, Modern Radar or Chart plotter for displaying AIS data on a more advanced display than the TR-8000 Display unit, which only gives you basic text/graphic information.

On modern ECS, Radars, Chart plotters etc. the vessels received by the TR-8000 will be shown as a separate “Layer” or “Overlay” with configurable alarms on collision probability (CPA/TCPA) together with high resolution accurate charts.

The TR-8000 Transponder unit can be connected in three different ways:

1. RS422 (Default) , connections 4-9
2. RS232 , connections 42-44
3. Ethernet (UDP), connected either instead of the TR-8000 display unit, or together with a network Switch in parallel with the Display Unit

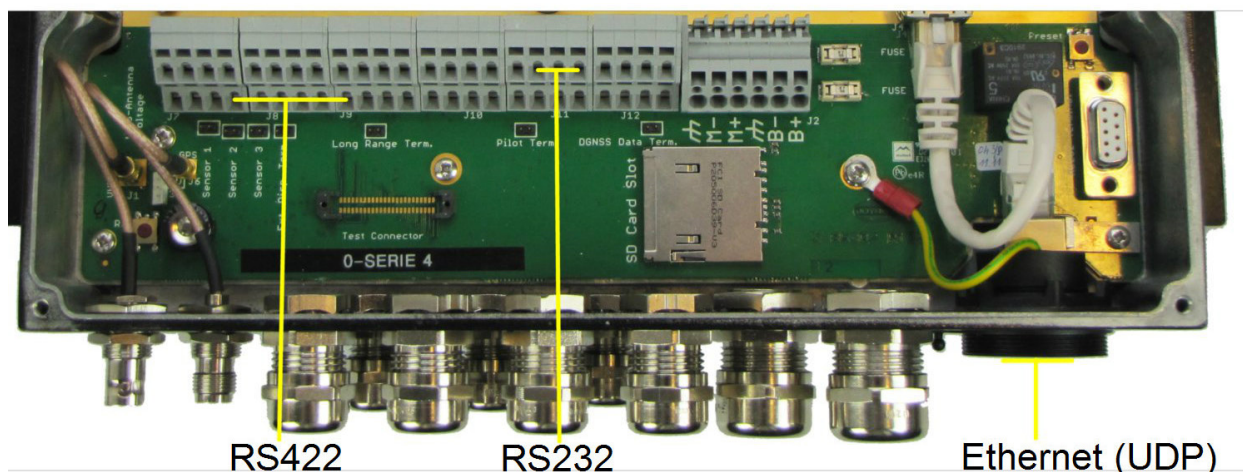

Figure 8-13 External display connections

See also chapter 10.2.1.2 which describes how to configure “External Display” options and table in chapter 8.3.1.2 for details of pinouts

Default speed on this port is 38400 baud.

#	In/Out	Type	Usage	Name
4	In	RS422	External Display	RD2-B(+)
5				RD2-GND (Iso Gnd)
6	In			RD2-A(-)
7	Out			TD2-A(-)
8				TD2-GND (Iso Gnd)
9	Out			TD2-B(+)

42	Out	RS232	External Display	TX (Transmit)
43	In			RX (Receive)
44				232-GND(Ground)

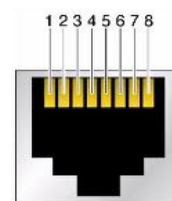

Figure 8-14 Ethernet RJ45 connector

#	In/Out	Type	Usage	Name
1	Out/In	Ethernet (UDP) 100Base-T	TR-8000 Display Unit Or External Display	TX+ / RX+
2	Out/In			TX- / RX-
3	In/Out			RX+ / TX+
4	-			-
5	-			-
6	In/Out			RX- / TX-
7	-			-
8	-			-

Please note! The “Ethernet” interface is auto detecting RX and TX similar as a network switch. You don’t need to think about crossed cable or not !

8.3.1.6 Pilot / Aux. Display connection

This Port may be mandatory to be used with Pilot port connector (See picture below) on some kind of vessels. Otherwise, this port may be used to connect a secondary display (Maybe ARPA radar, if “External display” is connected to ECS/ECDIS)

This port is one of two options to connect a Pilot connector, as it is also possible to connect Pilot port cable to the TR-8000 Display Unit, see chapters 8.3.2 and 10.2.1.3

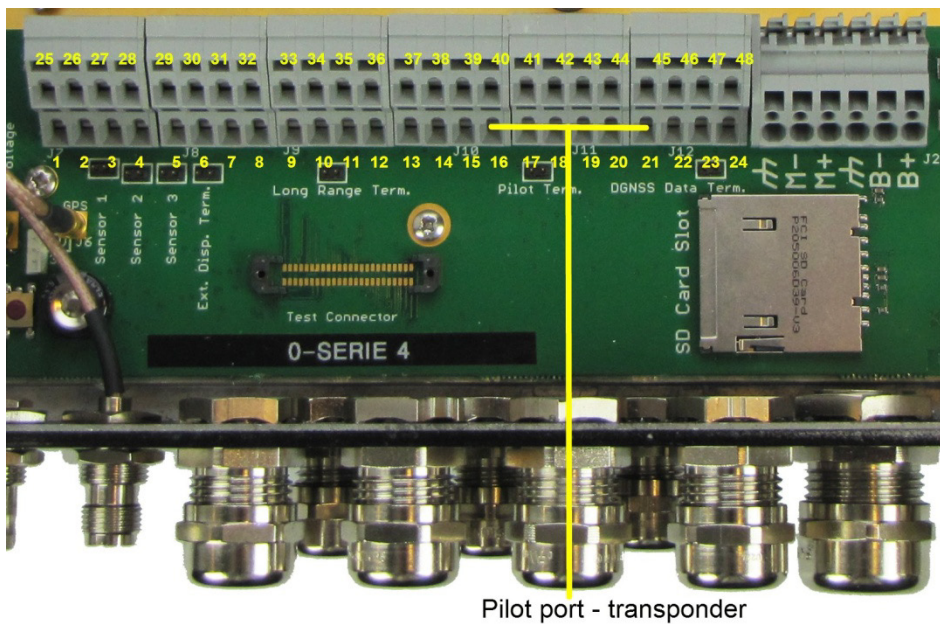

Figure 8-15 Pilot plug with cable

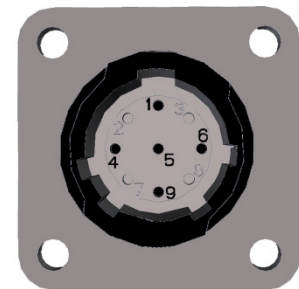

Figure 8-16 AMP 206486-1 (Pilot Plug) pinout

Default speed on this port is 38400 baud.

#	In/Out	Type	Usage	Name	Connects to AMP 206486-1 Pin no:
16	In	IEC61162-2 (RS422)	Pilot / Aux Display	RD4-B(+)	6
17				RD4-GND (Iso Gnd)	9
18	In			RD4-A(-)	5
19	Out			TD4-A(-)	1
20				TD4-GND (Iso Gnd)	
21	Out			TD4-B(+)	4

8.3.1.7 Alarm Connection

Below picture shows where to connect external alarm to TR-8000

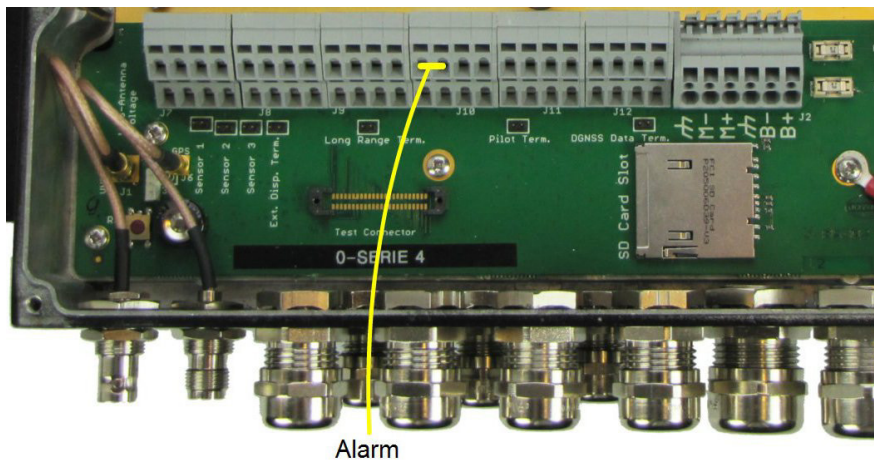

#	In/Out	Type	Usage	Name
37	Out	Relay (NC)	Alarm	ALARM_A
38	Out			ALARM_B

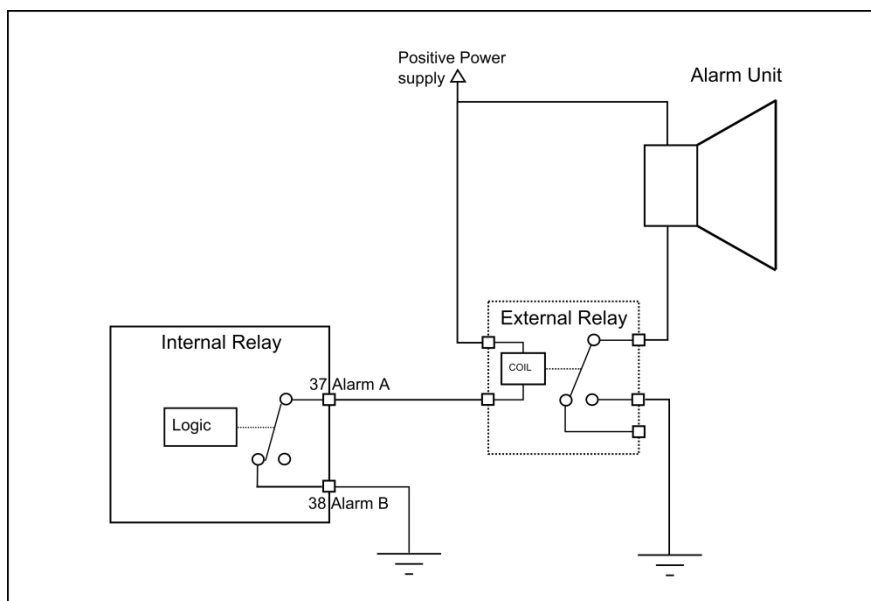

Figure 8-17 Typical Alarm connection

In this configuration, both the external relay and the alarm unit are powered from external power source, and the alarm unit is grounded through the external relay if an alarm occurs or the main power to the AIS is removed or defective.

Other configurations may be used, but remember that the Alarm must function both on AIS Alarm conditions, and power failure to the AIS.

The internal alarm relay is a normally closed earth free relay contact, provided as an independent and simple method for triggering an external alarm. This means that when the transponder is powered and there are no alarms, the contact is considered closed. If an alarm occurs or power is lost, the contact is considered open, as also will be the case when the wiring is incorrect or broken. The internal alarm relay will close when the alarm is acknowledged. If transponder power is lost or the wiring to the internal alarm relay is broken, the only way to deactivate the Alarm is to disconnect the power source of the Alarm relay. The internal alarm relay is capable of driving a 2A current. The maximum voltage over the internal alarm relay must not exceed 48V.

8.3.1.8 Detailed description of connections, fuses, factory reset etc.

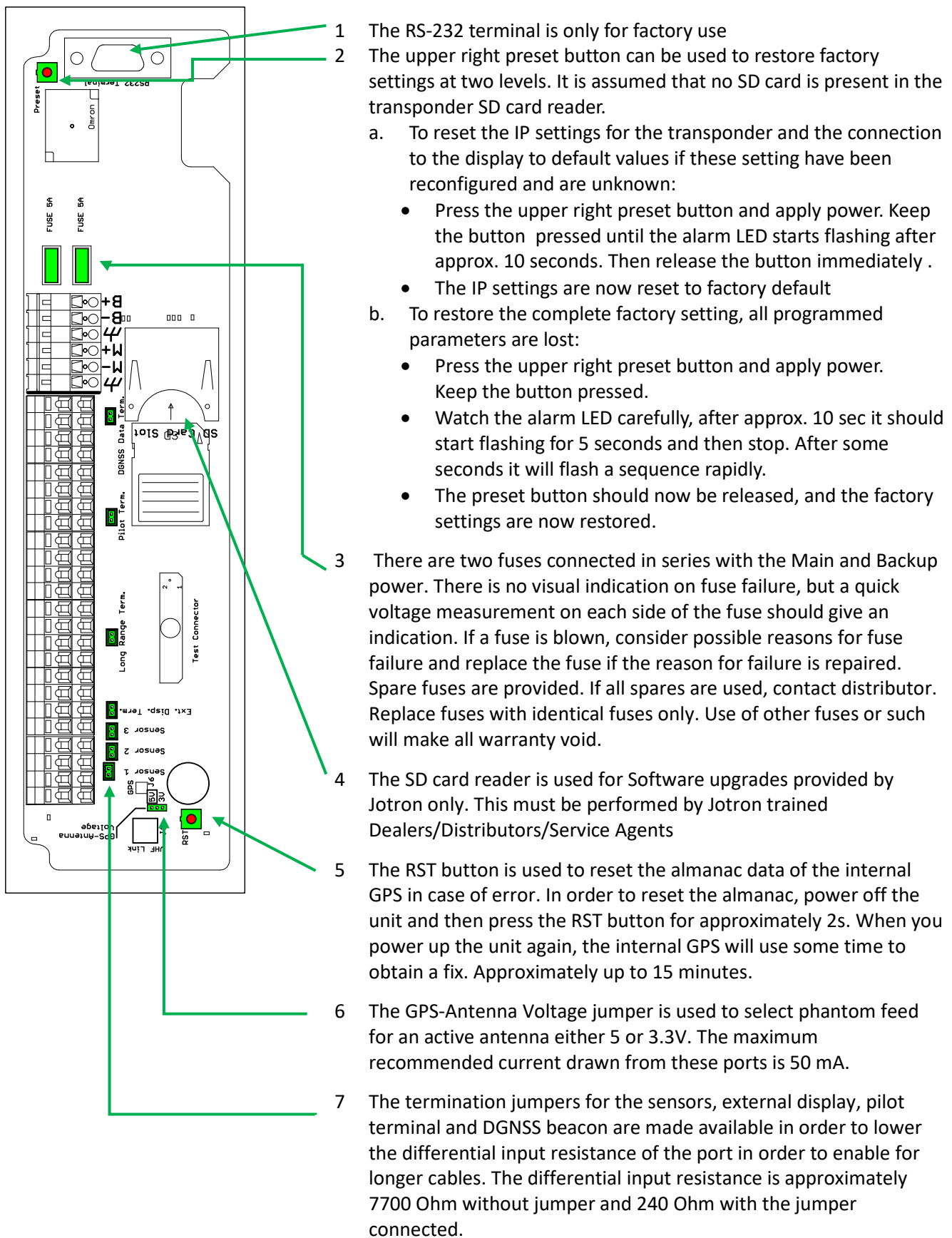

- 8 Default Transponder IP address: 10.0.0.10
- 9 Default Display IP address:10.0.0.11

8.3.2 Display Unit:

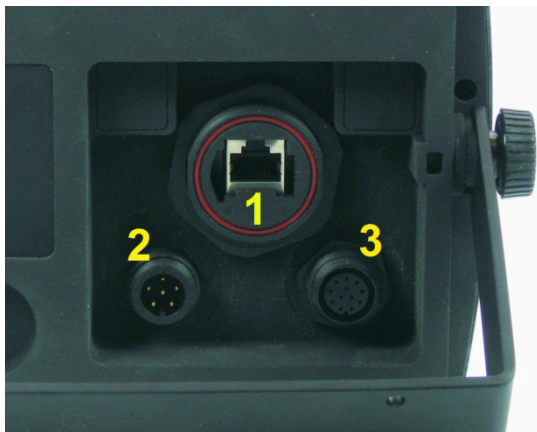

The TR-8000 Display Unit has three different connectors on the rear

#	Description	Type	Pins	Mating Plug/Socket	Manufacturer	Other
1	Transponder	Ethernet Buccaneer/ Jotron	8	Jotron Partno: 86145	Bulgin	Std delivery: 5m cable with Ethernet Buccaneer in each ends. See 8.2.3
2	Power	Buccaneer	6	PX0410/06/S	Bulgin	Jotron made cable, Partno: 86581
3	Pilot	Buccaneer	12	PX0410/12/P	Bulgin	Jotron made cable, Partno: 86870

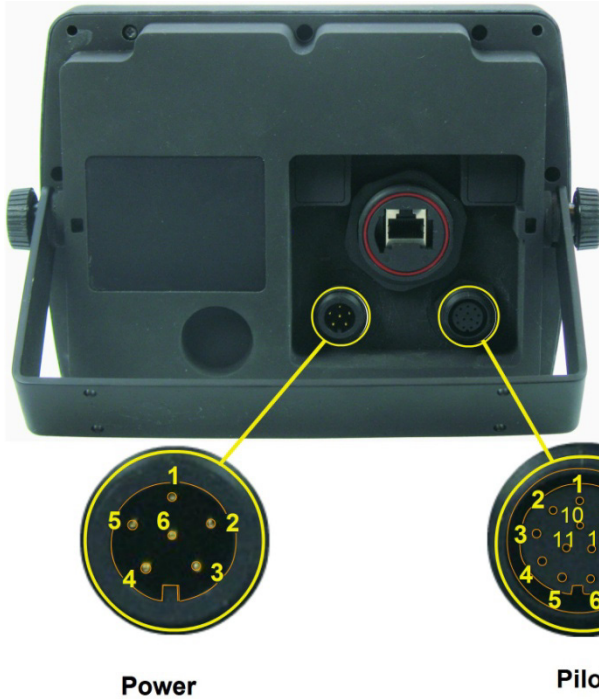

The cable between transponder and display is described in chapter 8.2.3 and below is the “Power” and “Pilot” connectors described.

The type of mating connectors are described in the table on previous page.



Figure 8-18 Partno.: 86870, Pilot plug cable, Display Unit



Figure 8-19 Partno.: 86581, Power cable, Display Unit

Below is a table showing pinouts for the two connectors:

Power (86851):

#	Name	Colour
1	MAIN 12 - 24 VDC	Green
2	GND (Chassis)	Shield
3	BACKUP 12 - 24 VDC	Yellow
4	BACKUP 0 VDC	Brown (common with 5)
5	MAIN 0 VDC	Brown (common with 4)
6	Do Not connect	

Pilot (86870):

#	Name	Connects to AMP 206486-1 Pin no:
1	Floating Ground	
2	TDA Out	1
3	TDB Out	4
4	Floating Ground	9
5	RDA In	5
6	RDB in	6
7-12	Do Not Connect	

The Pilot connector may either be connected to the Display Unit as described here, or to the transponder unit as described in chapter 8.3.1.6

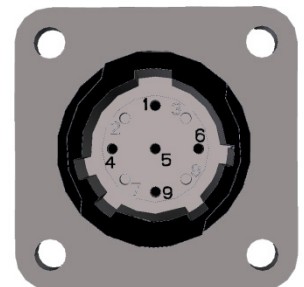

Figure 8-20 AMP 206486-1 Pinout



Figure 8-21 Ethernet RJ45 connector

Transponder (RJ45):

#	In/Out	Type	Usage	Name
1	Out/In	Ethernet (UDP) 100Base-T	TR-8000 Display Unit Or External Display	TX+ / RX+
2	Out /In			TX- / RX-
3	In/Out			RX+ / TX+
4	-			-
5	-			-
6	In/Out			RX- / TX-
7	-			-
8	-			-

Please note! The Transponder “Ethernet” interface is auto detecting RX and TX similar as a network switch. You don’t need to think about crossed cable or not !

9 Initial configuration

9.1 Short reference for initial configuration

- Fill in **Own Ship** (Ch. 10.1.1)
 - Ship Name
 - IMO number
 - MMSI –“-
 - Call Sign
 - GPS antenna positions (Internal & external)
 - Type of Vessel
- Check **GPS and position**:
 - internal GPS signal strength (ref ch. 10.2.4)
 - Current position: (Ref ch.10.2.8)
- Configure **External Display Interface**(ch. 10.2.1.2)
 - RS422, RS232 or Ethernet
- Configure **Pilot port interface**(ch. 10.2.1.3)
 - Display or Transponder
- Check **External Sensor communication**
 - Indicators (ch. 10.1.4) - shows Sensors detected
 - Port Monitor (ch. 10.2.1.6) – shows RAW data from Sensor 1 to Sensor 3
- Check **External Display communication** (ch.8.3.1.5)
- Check **Communication test** (ch. 10.2.2.5)
- Fill in **Voyage Settings** (Ch. 7.3)
 - Navigational status
 - Destination
 - ETA
 - Draught
 - Cargo Category
- Check **reception of ship in ship list** – normal operation (ch. 7.2.6)



9.2 Not all ships carry AIS

It is important to remember that not all ships carry AIS, in particular leisure crafts, fishing boats, warships and some coastal shore stations including Vessel Traffic Service Centers.

9.3 Use of AIS in collision avoidance

As an anti-collision aid the AIS has some advantages over radar:

- Capable of instant presentation of target course alternations.
- Not subject to target swap.
- Not subject to target loss in clutter.

- Not subject to target loss due to fast manoeuvres.
- Able to detect ships within VHF/FM coverage.

IMPORTANT

When using the AIS for anti-collision purposes it is important to remember that the AIS is an additional source of navigation information. It does not replace other navigational systems. The AIS may not always give the right picture of the traffic in your area separately.

9.4 Erroneous information

Erroneous information implies a risk to other ships as well as your own. Incorrectly configured or calibrated sensors might lead to transmission of incorrect information. It is the user's responsibility to ensure that all information entered into the system is correct and up to date.

10 Operation Instructions

10.1 Configuration Menu

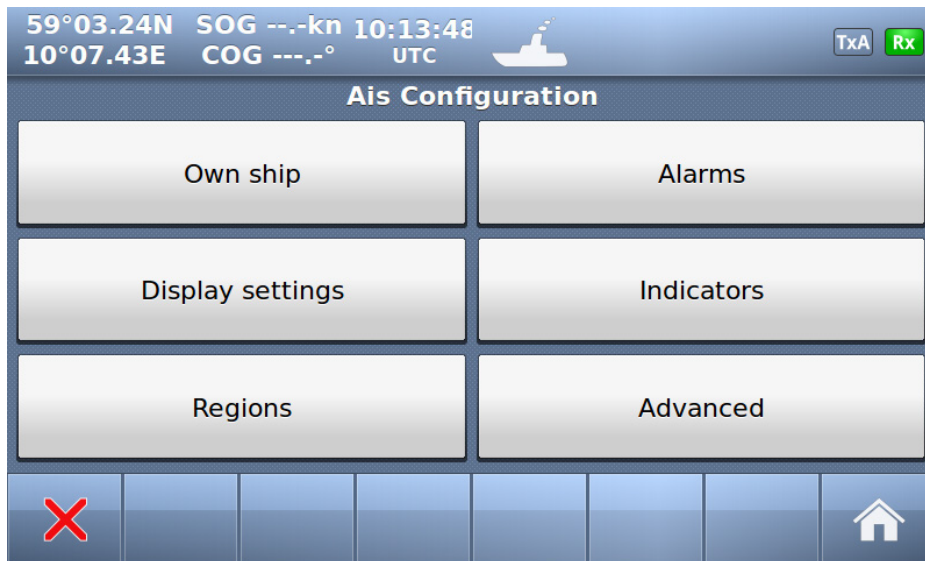

The AIS configuration menu consists of six menus, containing the settings and configurations most applicable to the user. Some settings are write-protected by administrator password, but the user is always allowed to view the current settings.

10.1.1 Own Ship

The own ship configuration is for setting the static data of the ship and is primarily only used during setup/installation but should also be checked regularly (at least once a month).



See available settings on the display shown here

To be able to change values, the **Admin pswrd** button must be pressed and the password must be entered (Default: SE)





Vessel name, Call sign, MMSI and IMO are all text or numbers and may be entered easily

10.1.1.1 Type of Vessel

59°03.25N SOG ---kn 11:54:10
10°07.43E COG ---,° UTC  TxA Rx

Vessel type (1 of 3)

<input type="radio"/> Cargo ship (70)	<input type="radio"/> Sailing (36)	<input type="radio"/> Pilot (50)
<input checked="" type="radio"/> Tanker (80)	<input type="radio"/> Pleasure craft (37)	<input type="radio"/> Tug (52)
<input type="radio"/> Passenger ship (60)	<input type="radio"/> Fishing (30)	<input type="radio"/> Towing (31)





- Select Type of Vessel
- Confirm with 

If the correct vessel type cannot be found on the first page, it is possible to move between three vessel type pages by using the arrow keys in the middle of the button bar.

59°03.25N SOG ---kn 11:54:46
10°07.43E COG ---,° UTC  TxA Rx

Vessel type (2 of 3)

<input type="radio"/> Large towing (32)	<input type="radio"/> Anti pollution (54)	<input type="radio"/> Diving op. (34)
<input type="radio"/> Search & rescue (51)	<input type="radio"/> Law enforcement (55)	<input type="radio"/> Dredging op. (33)
<input type="radio"/> High speed craft (40)	<input type="radio"/> Port tender (53)	<input type="radio"/> Military op. (35)





Caution!

Vessel types that does not have a first digit of 3 or 5 will have their definition completed by selecting the proper cargo type from the Voyage settings dialog ([see 7.3.5](#)). If such a selection is not done, the ship will have it's second digit set to 9 (No additional info.)

59°03.25N SOG ---kn 11:55:18
10°07.43E COG ---,° UTC  TxA Rx

Vessel type (3 of 3)

<input type="radio"/> Medical transport (58)	<input type="radio"/> Local vessel (56)
<input type="radio"/> Resolution 18 ship (59)	<input type="radio"/> Local vessel (57)
<input type="radio"/> Wing in ground (20)	<input type="radio"/> Other ship (90)

10.1.1.2 Ship Dimension and Antenna Position

In order to calculate the correct location of own ship relative to other ships, the exact position of the GNSS antennas and the dimension of the ship need to be specified.

The setting of the Ship Dimensions and the Antenna positions are combined as follows:

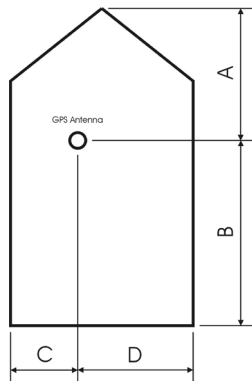

A: Distance from bow to GPS antenna position in meters.

B: Distance from stern to GPS antenna position in meters.

C: Distance from port to GPS antenna position in meters.

D: Distance from starboard to GPS antenna position in meters.

Figure 1: Ship Dimension and GPS antenna position.

Both the position of the internal and the external GPS antenna need to be set
To configure “GPS Antenna position”, select directly on the Touch screen:

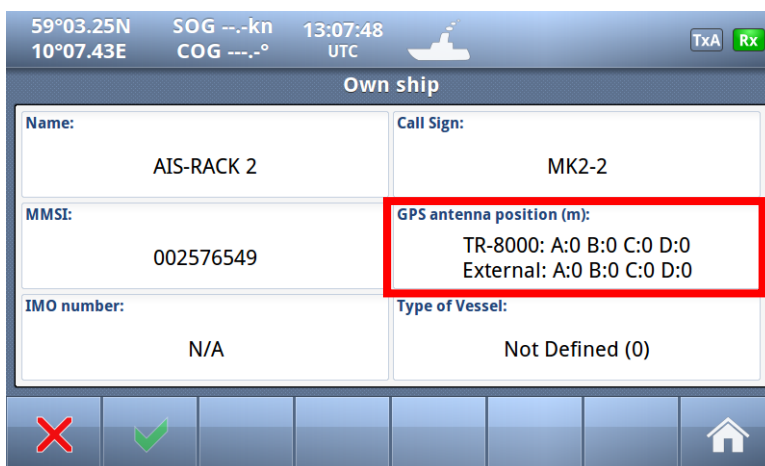

Red square shows  button selected to get to next menu

TR-8000 -> means position of the antenna connected directly or via a signal splitter to the transponder.

External -> means the position of the GPS antenna which is connected to an external GPS which feeds IEC 61162-1

messages to the transponder.

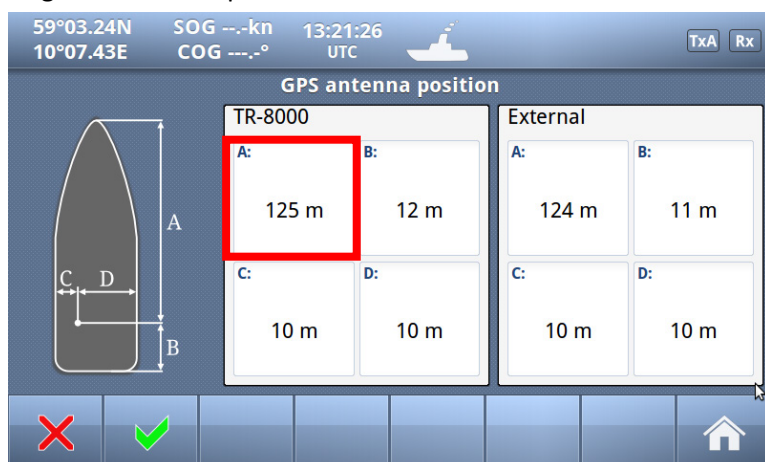

Click on “A”-“D” for “TR-8000” and “External” and input correct values. Then the length and width of the ship will also be defined

10.1.2 Display Settings



Red square shows button selected to get to next menu

10.1.2.1 Sleeping Targets

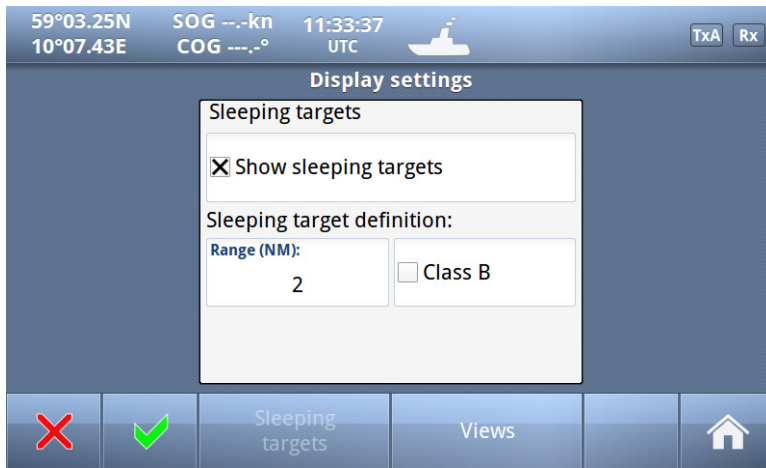

The first “Display settings” menu configures “Sleeping targets”. Sleeping target has a smaller shape and no vector in order to display a less cluttered graphic view. Sleeping targets can be defined to be all vessels outside a defined range, and/or all class B stations.

10.1.2.2 Views

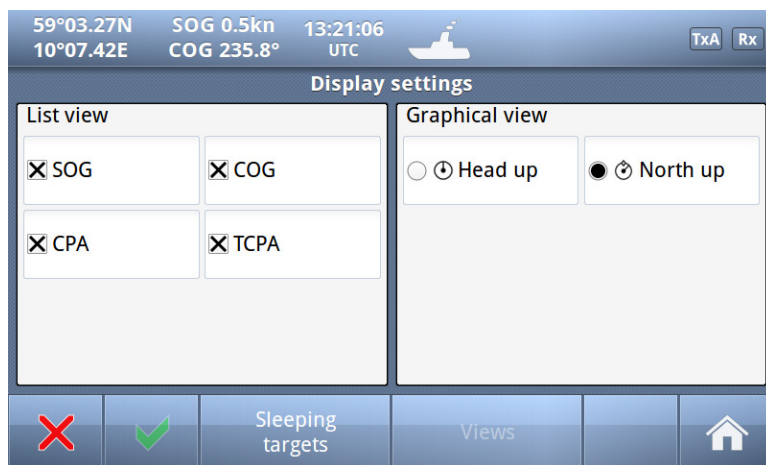

Press the View button on the button bar in order to configure how the ship list and the graphic view should be displayed.

Here we can configure which columns shall be shown in “Ships List” (chapter 7.2.6) and if we want “Head up” or “North up” in “Graphical view”(chapter 7.2.7).

10.1.3 Regional Settings

The Regional Settings are primarily used by local base stations to assign special frequencies or transmitter configurations for certain areas. It is also allowable to add or edit the regions, **but this should be done with caution, as incorrect frequency settings for an area will disable the functionality of the AIS system.** Altering the regional settings is protected by a user password. The Area named HIGH SEA, is the default area and contains the whole world, except from the other regions, if defined.

Each Region is defined by the following parameters:

- Area, defined as North East corner and South West corner
- Two channels used for VHF communications
- Rx/Tx mode is used to restrict the transmission to one of the two channels.
- Output Power is chosen between High or Low setting (1W or 12.5W)
- Transitional zone defines the area surrounding an area in order to switch the frequencies in a step by step order. The transitional zone defined between 1 and 8 NM

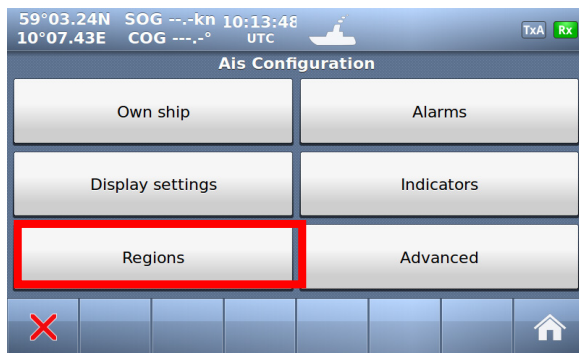

 Red square shows button selected to get to next menu

10.1.3.1 Current Region settings

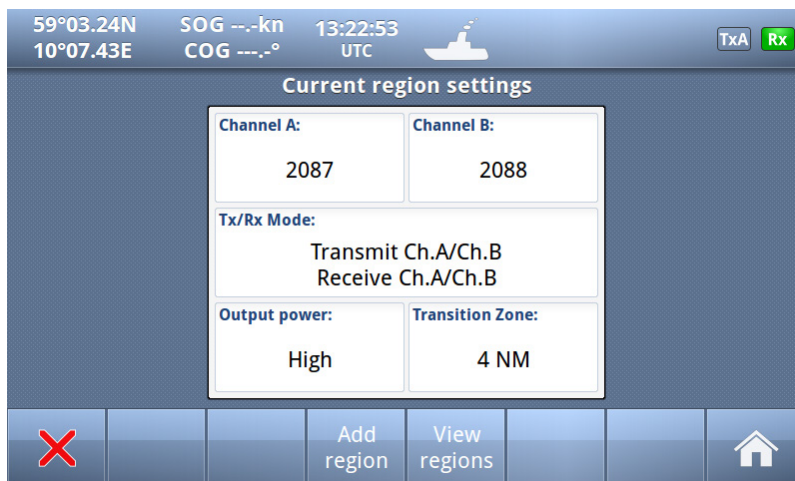

This is "Current Region settings" the TR-8000 is using now

From here, we can either "View" or "Add region"

10.1.3.2 View Regions

It is possible to view the settings of a given region by selecting a region in the regions list and pushing the View Region button.



Example of standard TR-8000 without any extra Regions defined

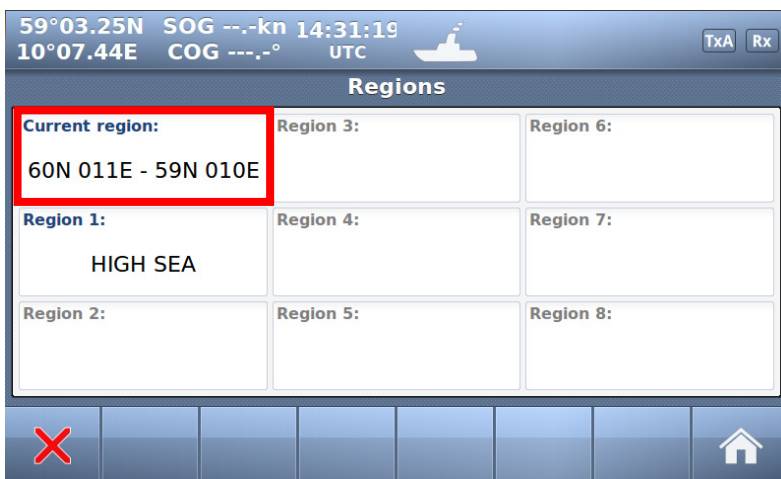

Example configuration with one extra Region defined

Red square shows  button selected to get to next menu

10.1.3.2.1 View Custom defined Regions

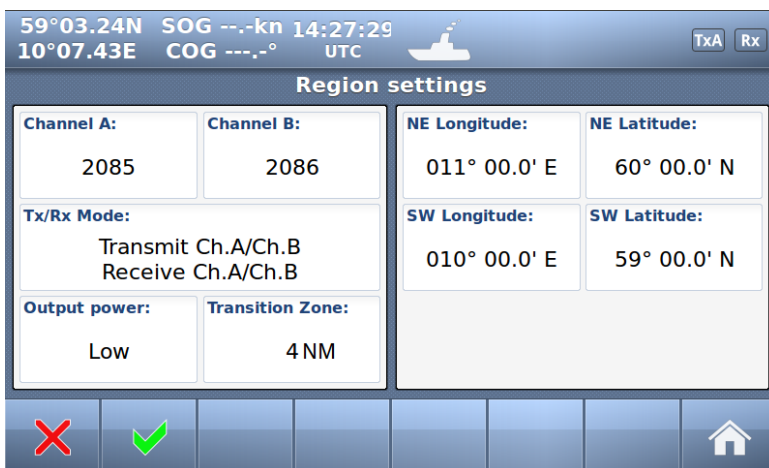

For Custom defined Regions (Either configured by the user of TR-8000 or configuration is received from an AIS Base Station in a special message) the Region have in addition North East position and a South West position defining the area in which the special settings of :

- Channels
- Tx/Rx mode
- Power
- Transition zone

10.1.3.3 Add Region

The user is allowed to Add Regions, but caution is advised (see **10.1.3**).

It is not allowed to delete regions, they will be deleted on timeout after 24 hours inactivity, if the ship is more than 500NM away from the region, or if the region is overwritten. There is a maximum amount of 8 regions in addition to the HIGH SEA region

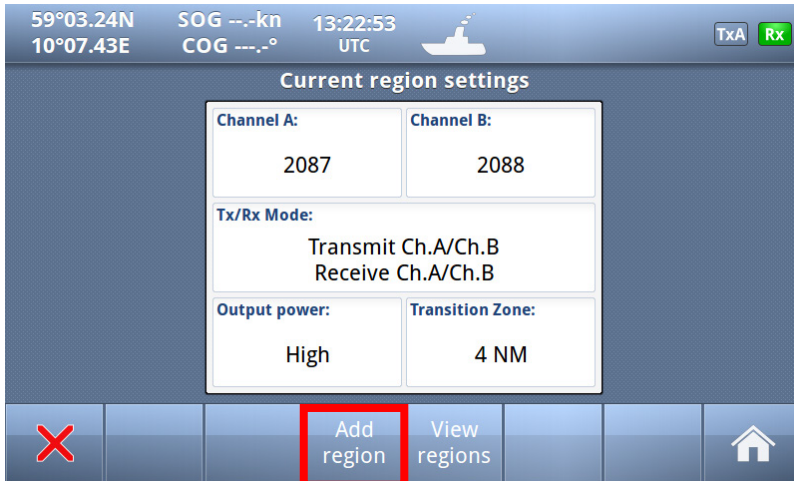

Red square shows  button selected to get to next menu

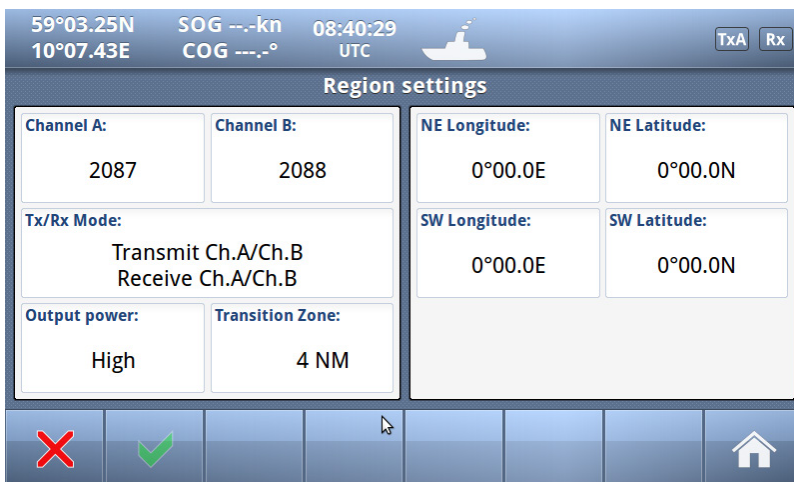

When “Add Region” is selected, default values for Channels, Tx/Rx Mode, Power and Transition zone are configured, but all these parameters may be altered together with defining position of the North East and South West corners of the Region.

10.1.3.3.1 Change Channel

NOTE! BE AWARE THAT SETTING OF CHANNELS WITHOUT SPECIFIC KNOWLEDGE OF CORRECT SETTING MAY ALTER YOUR AND OTHER VESSELS SECURITY AS:

- YOU MAY TRANSMIT ON ILLEGAL CHANNELS
- YOU MAY NOT BE SEEN ON OTHER VESSELS AIS
- OTHERS MAY NOT SEE YOU
- THIS CAN IN WORST CASE LEAD TO COLLISIONS

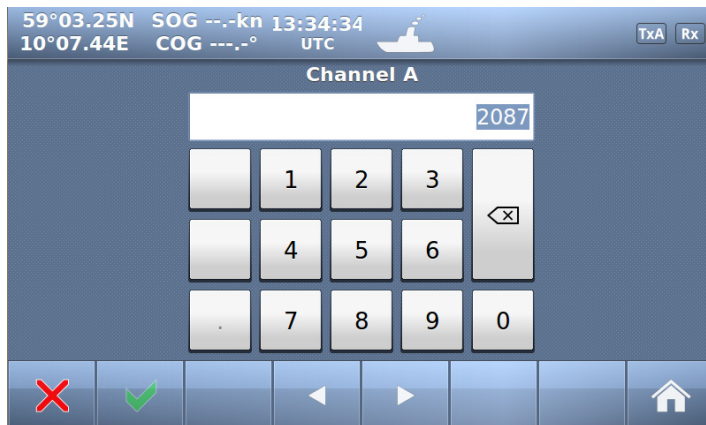

When you select either the buttons “Channel A” or “Channel B” you may input the correct channel number.

The default channels 2087 and 2088 are the same as 87B or 88B used previously as Coast Station frequencies on 161.975 MHz and 162.025 MHz.

See complete list in Chapter 12 and for updates of this list from ITU RR, Appendix 18

10.1.3.3.2 Tx/Rx Mode

Tx/Rx Mode allows you to change setting in which the transponders will use the two regional channels for transmission (Tx) and reception (Rx)

When you press the button “Tx/Rx Mode” it will toggle between the valid configurations:

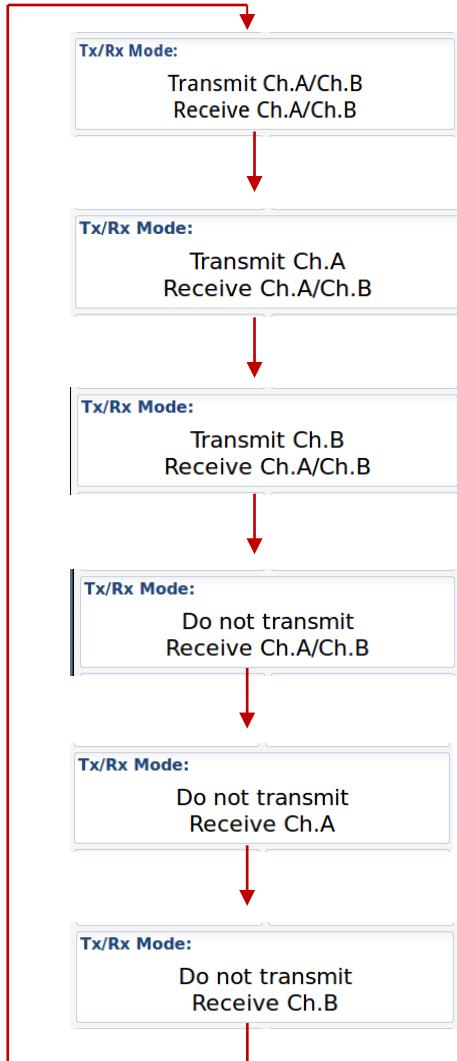

- Default – will transmit/receive on both channels

10.1.3.3.3 Output Power

The button “Output Power” will toggle between “High” and “Low” power:



10.1.3.3.4 Transition Zone

A Region must be between 20 and 200 Nautical miles and within this region there will be a “Transition zone” between 1 and 8 Nautical miles:

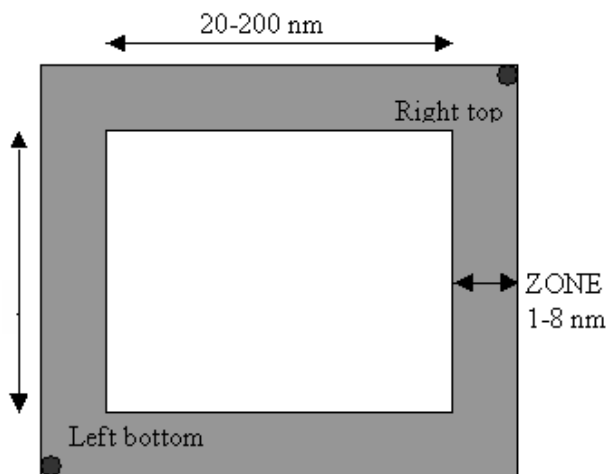

This zone is used for frequency transition so only one frequency is changed at a time. There are defined rules for how the AIS will behave through this zone.

The AIS will continuously monitor for its own position and range to the regional areas defined. When entering transition zone for Region 1, frequency is changed on the primary channel. The AIS is now sending the primary frequency defined for each of the regions.

When the boundary for the Region 1 is crossed,

the second frequency shall be changed. Then the primary frequency for the old region (or default setting) is switched with the secondary frequency for the new region. Then both frequencies have changed.

When entering another region, frequency transition is performed as described above with the frequencies (settings) of the new region. When leaving a region, frequency transition is performed back to default values.

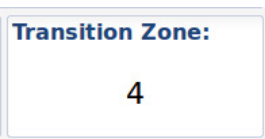

To change the value of this “Transition Zone”, select the button and input value between 1 and 8 (Nautical miles)

10.1.3.3.5 Define Region

A Region must be between 20 and 200 Nautical miles as described above and you must define the Longitudes and Latitudes of the South West and North East corners:

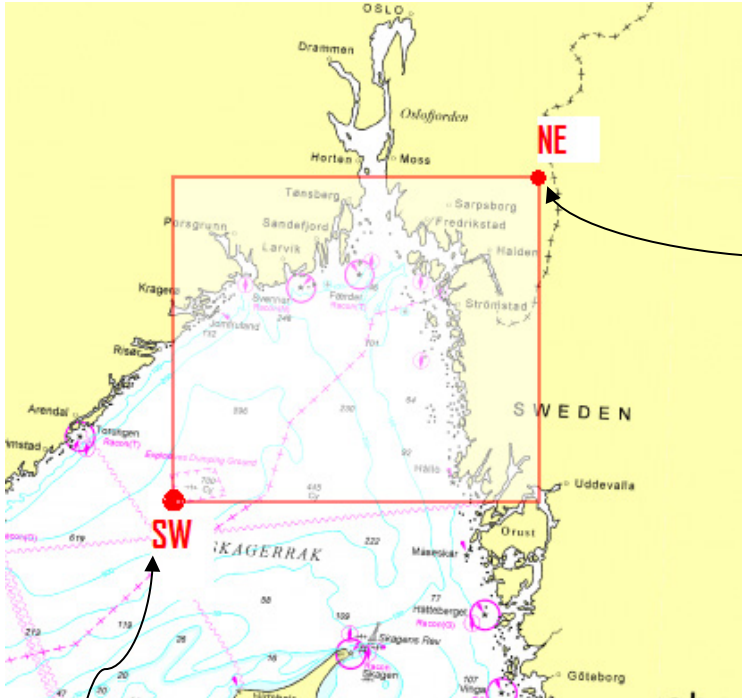

The values are defined by selecting these 4 buttons:

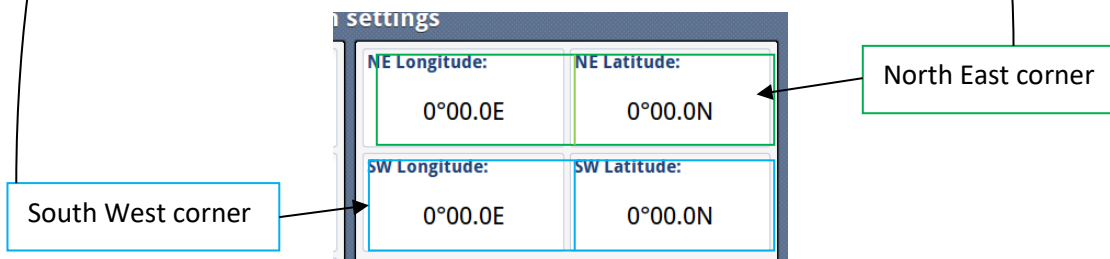

If the values are within 20 – 200 NM, they will be accepted, and you will be asked if you want to save it:

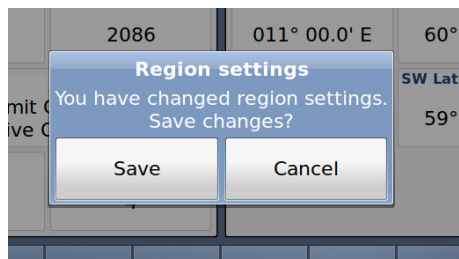

Otherwise you may experience errors:

10.1.3.3.5.1 Illegal Coordinates

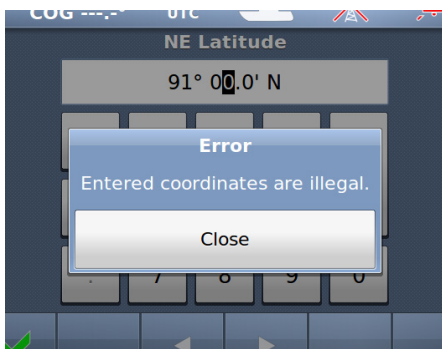

Example: Too large value for Latitude

10.1.3.3.5.2 Region Width /Height problem

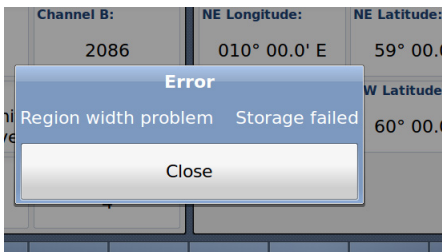

Example: Too large value for “Region width”

10.1.3.4 Alarms

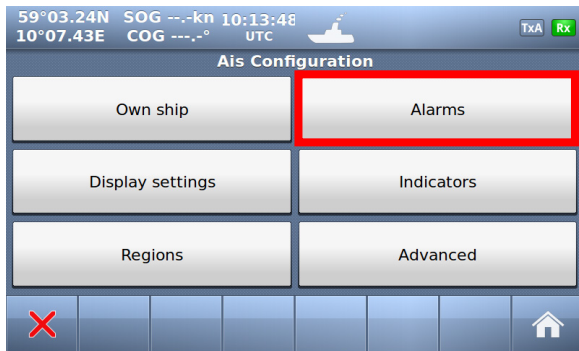

Red square shows  button selected to get to next menu



10.1.3.4.1 Alarm Popup

When Alarms occurs, a popup will be shown with status of Alarms:

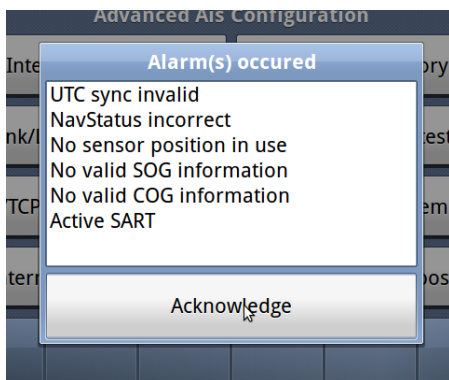

And the "Alarm" popup must be acknowledged by pressing the button below Alarm window

The internal Alarm is triggered if a failure is detected in one or more of the AIS functions or data. The corresponding message is given as in Table 2. The most probable source of error and corresponding system behavior is described together with some notes on troubleshooting the error.

Alarm ID	description text	Cause / Source of error	Reaction of the system and user advise
001	Tx malfunction	Internal frequency error* Alternatively Invalid MMSI	The Transponder stops transmission. Check that the MMSI number is correct. Alternatively, service is required.
002	Antenna VSWR (Voltage Standing Wave Ratio) exceeds limit	VHF antenna or installation	The Transponder continues transmission. Check the VHF antenna and the cabling. Make sure the cables are 50 Ohm
003	Rx channel 1 malfunction	Internal frequency error*	The Transponder stops transmission on the affected channel. Try rebooting the system Alternatively, service is required
004	Rx channel 2 malfunction	Internal frequency error*	The Transponder stops transmission on the affected channel. Try rebooting the system Alternatively, service is required.
005	Rx channel 70 malfunction	Internal frequency error*	The Transponder continues normal transmission but is not able to receive DSC messages. Try rebooting the system Alternatively, service is required.
006	General failure	Internal error	The Transponder stops transmission. Try rebooting the system. Alternatively, service is required.
007	UTC sync invalid	GPS antenna or installation	The Transponder continues operation using indirect or semaphore synchronisation with other AIS units. If the received GPS signal strength is low, the GPS might use some time to get the first fix. Consider waiting 15 minutes. Check the GPS antenna and cabling. If the antenna is an active type, check that the phantom DC voltage is correct

008	MKD connection lost	Connection between the Display Unit and the Transponder is corrupted	<p>The Transponder continues operation, and alerts other AIS systems that no display is present.</p> <p>Check that the display is turned on.</p> <p>Check that the cable is correct connected in both ends.</p> <p>Check the IP address and corresponding communications IP address of both units if using the Ethernet connection.</p> <p>Check for firewall error or such if connected through a local network.</p>
009	Internal / external GNSS position mismatch	Internal or External GPS or Antennas	<p>The Transponder continues operation, but as this might imply that wrong position is used. Care should be taken as this might impose a risk both for own and other ships.</p> <p>Check the positioning of the GPS antennas.</p> <p>Disconnect the External GPS and check if the internal GPS provides the correct position.</p>
010	Navigational Status incorrect	Setup or speed sensor (Navigational status does not correspond with the given speed)	<p>The Transponder continues operation.</p> <p>Check that navigational status is not at anchor, moored or aground while SOG > 3knots.</p> <p>Check that navigational status is not under way while SOG = 0 knots.</p> <p>Check that SOG is correct.</p>
011	Heading sensor offset	COG sensor / HDT sensor Alarm ID 11 is activated when SOG is greater than 5 knots and the difference between COG and HDT is greater than 45 degrees for 5 min.	<p>The Transponder continues operation.</p> <p>Alarm indicates mismatch between Course over ground and True heading. Check sensors. If current speed is <5knots, check SOG</p>
014	Active AIS SART	AIS Search and rescue beacon activated	<p>The Transponder continues operation.</p> <p>Contact local RCC (Rescue Coordination Centre). Be prepared to assist in search and rescue operation.</p> <p>Listen on VHF channel 16 for additional information.</p>
025	External EPFS lost (External Satellite Positioning System)	No valid position data on sensor ports	<p>The Transponder continues operation with the internal GPS receiver. If no valid position is present on the internal sensor, ALR26 is also displayed.</p> <p>Check antenna and connections for EPFS, check sensor. Check baud rate settings.</p>
026	No sensor position in use	Internal and external GPS sensor	<p>The Transponder continues operation.</p> <p>Check cabling and antenna for the internal GPS sensor. At start up the GPS might need some time to receive almanac data. Up to 15 minutes might be required.</p>
029	No valid SOG information	Internal and external speed sensor	<p>The Transponder continues operation using default data.</p> <p>Check wiring and external sensor.</p> <p>Check baud rate settings.</p>
030	No valid COG information	Internal and external course sensor	<p>The Transponder continues operation using default data.</p> <p>Check wiring and external sensor.</p> <p>Check baud rate settings.</p>

032	Heading lost/invalid	External heading sensor	The Transponder continues operation using default data. Check wiring and external sensor. Check baud rate settings.
035	No valid ROT information	External rotation sensor	The Transponder continues operation using default data. Check wiring and external sensor. Check baud rate settings.

Table 2: Integrity alarm conditions signaled using ALR sentence formatter.

***The Tx/Rx Alarm is triggered if one of the internal frequency generators is out of lock, making the transmitter or receiver unable to function at the correct frequency.**

10.1.3.5 Alarm Relay Output

The internal alarm relay is a normally closed earth free relay contact, provided as an independent and simple method for triggering an external alarm. This means that when the unit is powered on, and there are no pending alarms, the internal relay will be closed. Otherwise, if an alarm is active, the internal relay is considered open. The internal alarm relay is deactivated upon acknowledgment of an alarm, either by the display unit, or by an externally provided ACK sentence. See section 8.3.1.7 for more details.

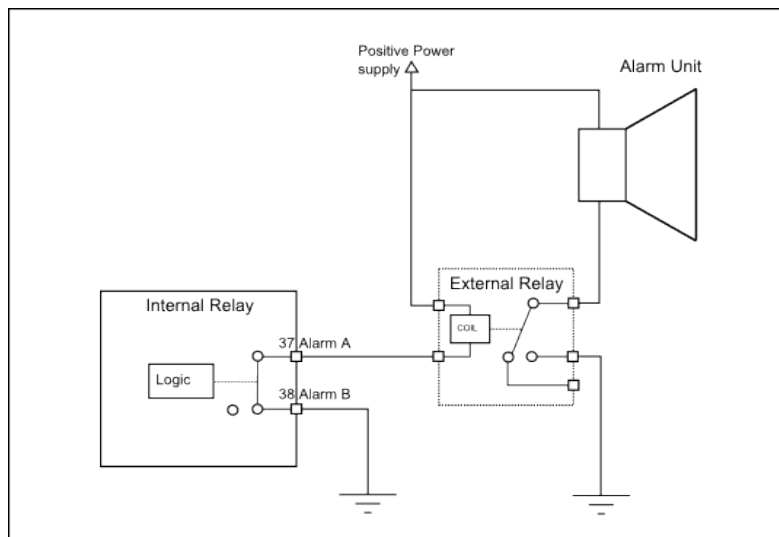
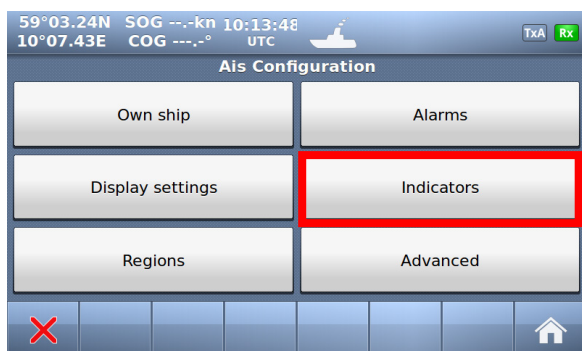
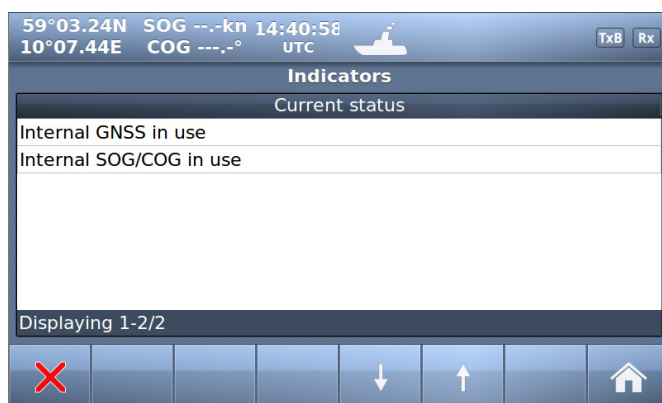

Figure 10-1 Typical Alarm connection

10.1.4 Indicators



Red square shows button selected to get to next menu





The *indicators* show information about where sensor data are collected, valid Heading etc. This list may be used if troubleshooting of the sensors is needed. The available messages are as given in .

Text Identifier	“Indicators” (Shown on Display unit and also sent as text message to ECS/ECDIS or other equipment connected to PI port)	Description
021	External DGNSS in use	DGNSS is normally the same as DGPS, which indicates external type of such sensor is in use
022	External GNSS in use	GNSS is normally the same as GPS, which indicates external type of such sensor is in use
023	Internal DGNSS in use (beacon)	Internal DGNSS (DGPS) (beacon) in use indicates a DGNSS beacon receiver is connected and transmit valid data to TR-8000
024	Internal DGNSS in use (Message 17)	Internal DGNSS (DGPS) (Message 17) in use indicates Differential correction data is sent from an AIS Base Station to this TR-8000 transponder
025	Internal GNSS in use	The inbuilt GNSS (GPS) receiver is in use
027	External SOG/ COG in use	SOG (Speed Over Ground)/ COG (Course Over Ground) from external GNSS(GPS) device is in use
028	Internal SOG/ COG in use	SOG (Speed Over Ground)/ COG (Course Over Ground) from internal GNSS(GPS) device is in use
031	Heading valid	True Heading is received from either an external Gyro or Satellite compass
033	(ROT) Rate of Turn Indicator in use	ROT received from external sensor: TI (Turn Indicator)
034	Other ROT source in use	No TI(Turn Indicator) from external sensor, ROT(Rate of Turn) value is calculated from HDT internally
036	Channel management parameters changed	If either “Region setting” is applied manually or from msg received from AIS Base Station, this indicator will be shown.

Table 3: Indicators.

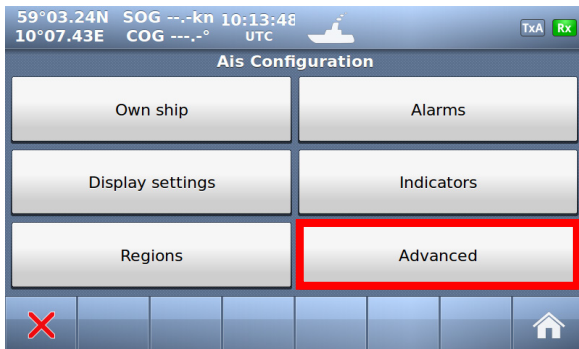
10.2 Advanced Menu



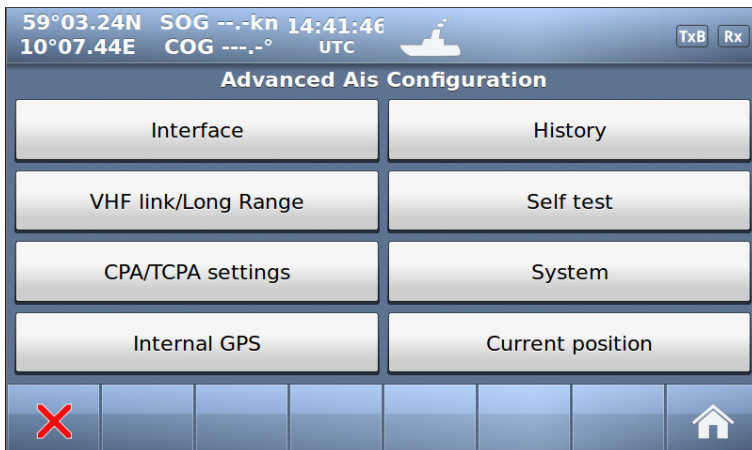

Red square shows  button selected to get to next menu

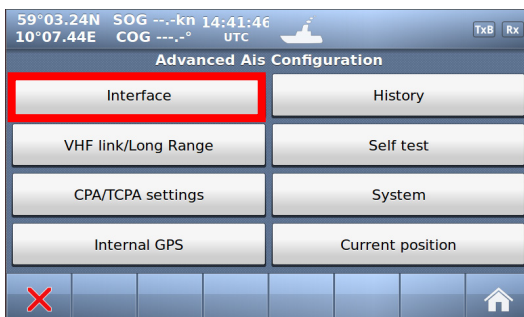

The **Advanced Menu** is intended for use during setup and maintenance of the TR-8000 AIS system. Some of the menus are write protected by password, but all parameters are readable to all users for inspection.

10.2.1 Interface



Red square shows  button selected to get to next menu

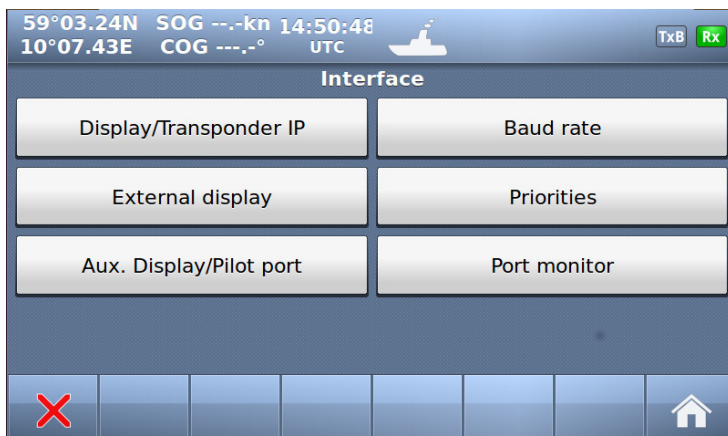

In the "Interface" menu, the parameters shown on the left picture can be configured.

10.2.1.1 Display/ Transponder IP

NOTE! Since the TR-8000 uses Ethernet between transponder unit and display, an IP addresses must be correctly configured

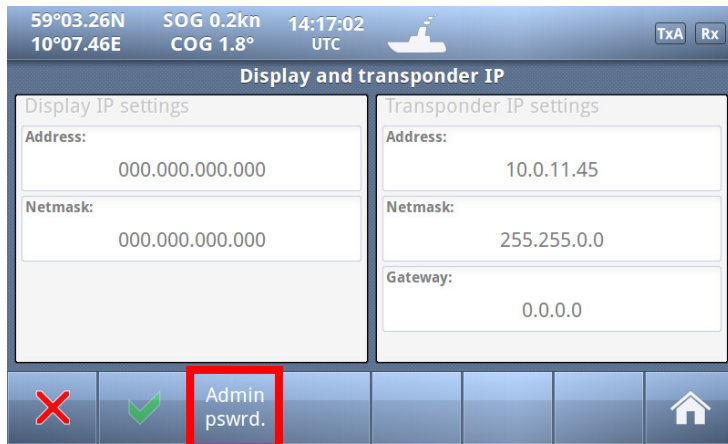

All parameters /buttons are “grayed out” as they are not accessible without “Admin Pswrd”

When “Admin pswrd” button is selected, the following window appear:



Input the “Admin Password” (SE) into the field and press the “Confirm” button:



Then it is possible to access all fields and configure IP correctly:

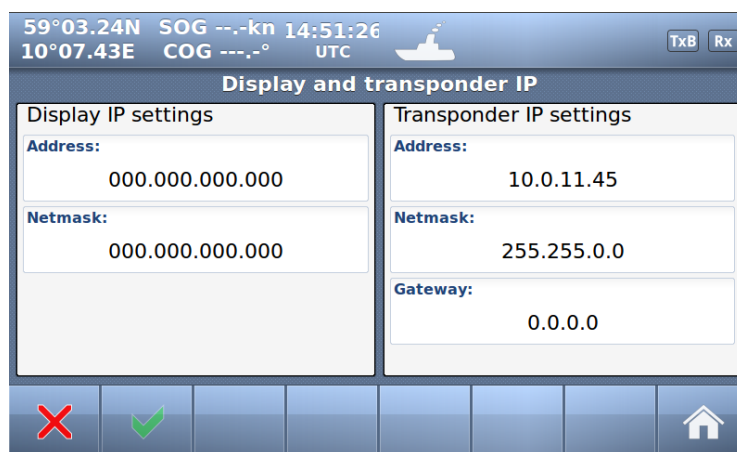

Default values are:

Display:

Address: 10.0.0.11
Mask: 255.255.0.0

Transponder:

Address: 10.0.0.10
Mask: 255.255.0.0
Gateway: 0.0.0.0

(Gateway is only used if Transponder communicates through a router that performs NAT (Network Address Translation). Then the Router address must be written here as “Gateway”)

And when configuration is finished either of “Return” or “Confirm”



buttons will bring you back to last menu.

10.2.1.2 External display

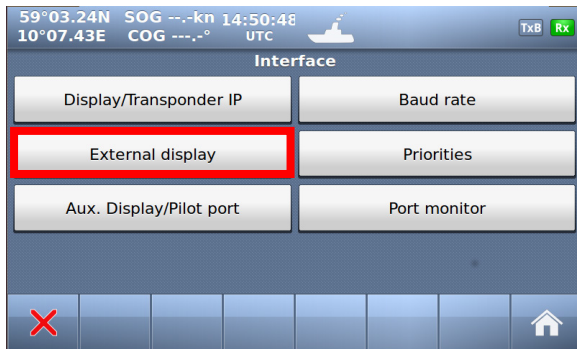

Red square shows  button selected to get to next menu

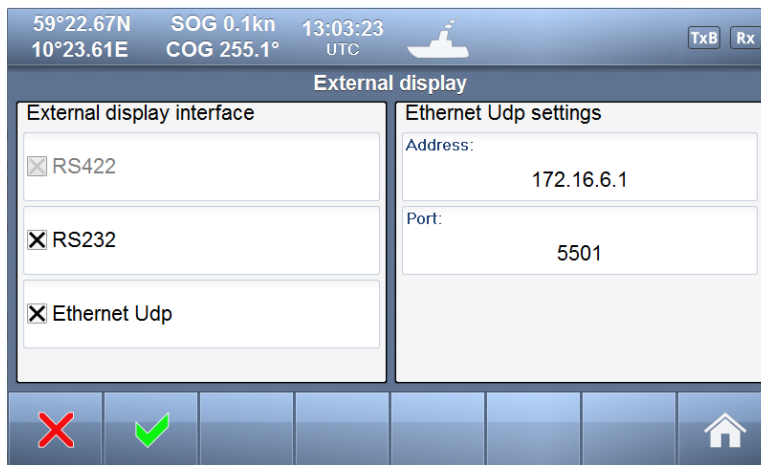

The TR-8000 supports up to three communication channels for data output. RS422 is always enabled, but if required, the RS232 port and ethernet UDP may be enabled and work at the same time.

When using UDP, the datagram is transmitted to the IP address shown in the dialog. The address may be in another subnet if a gateway is programmed in the interface settings.

If Ethernet is used, an external Ethernet switch is required for simultaneous connection of the display unit and a remote computer

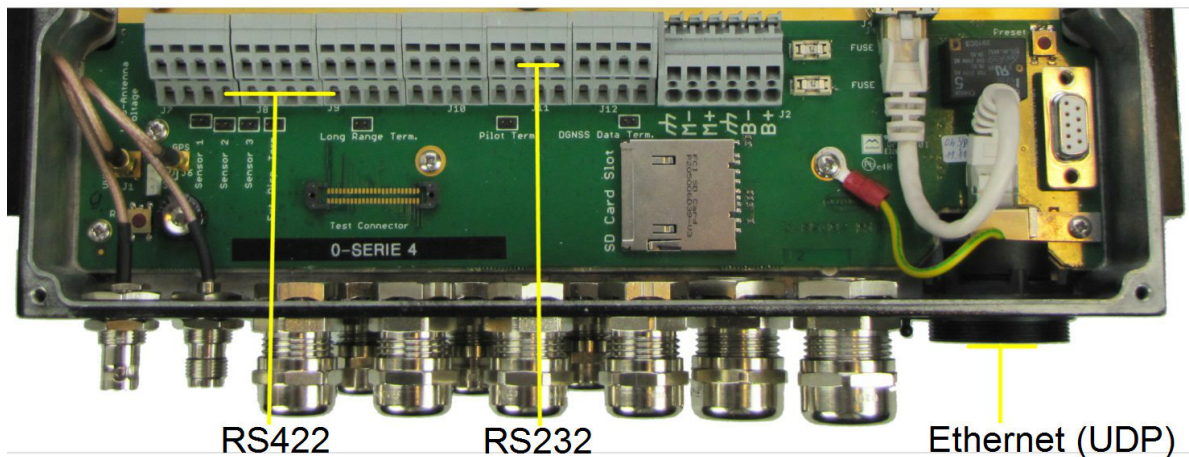

see also chapter 8.3.1.5 which describes the External Display physical connections

10.2.1.3 Aux. Display/Pilot Port

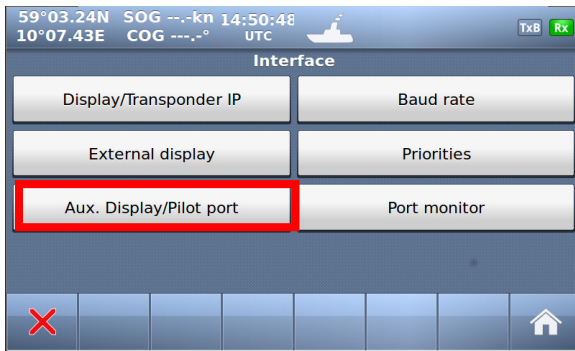

Red square shows  button selected to get to next menu

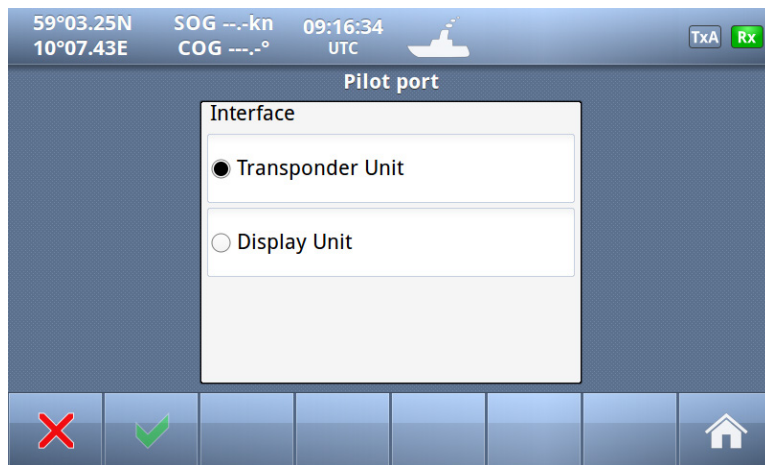

The TR-8000 has the flexibility of either connecting the Pilot port outlet to the Transponder unit or the Display unit, and therefore you may select which of the two option you want to use.

Below pictures shows where the physical connections are made.

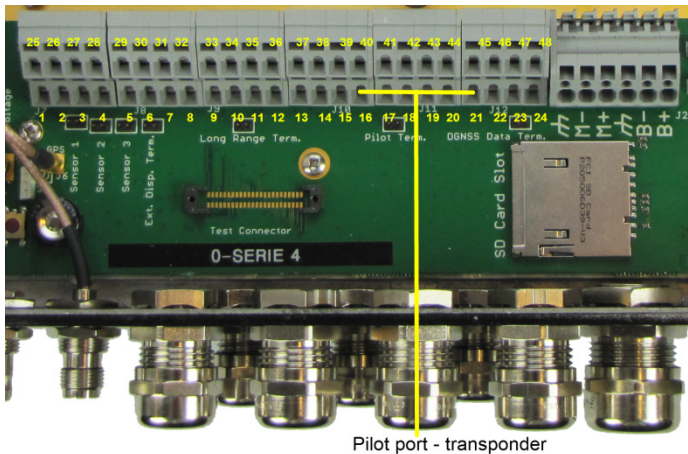

Figure 10-2 Pilot port connection, TR-8000 Transponder unit

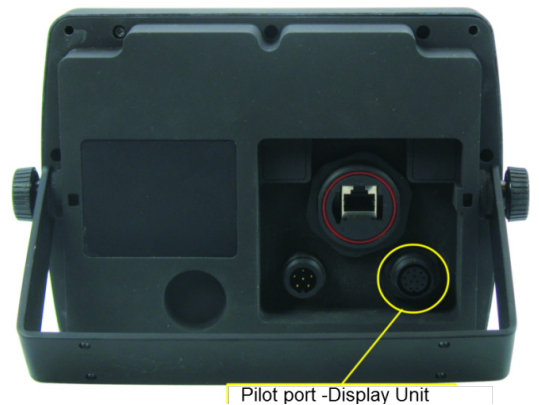

Figure 10-3 Pilot port connection, TR-8000 Display unit (rear)

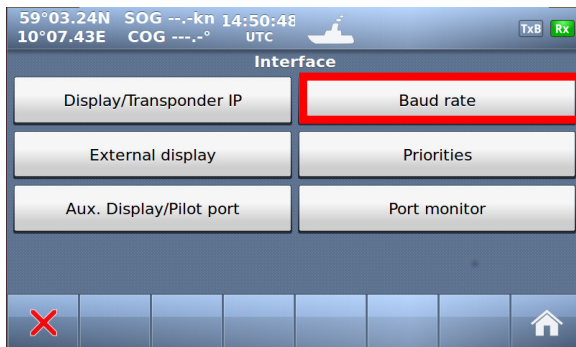



Figure 10-5 Pilot port cable, Transponder unit



Figure 10-4 Pilot port cable, Display unit

10.2.1.4 Baud rate



Red square shows  button selected to get to next menu



Press one of the 5 Port buttons to change the baud rate of that port. It will then jump between the legal options:

- 4800 (default: Sensor)
- 9600
- 19200
- 38400 (default: Long Range)

10.2.1.5 Priorities

From this menu the priorities for the different sensor measurements can be set individually. I.e if the unit receives Heading data from two different sources, the settings here specify what data source to be used.

In order to navigate through the different sensors, administrator password is required.

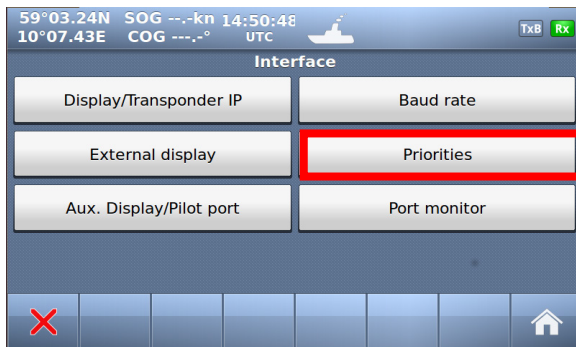

Red square shows  button selected to get to next menu

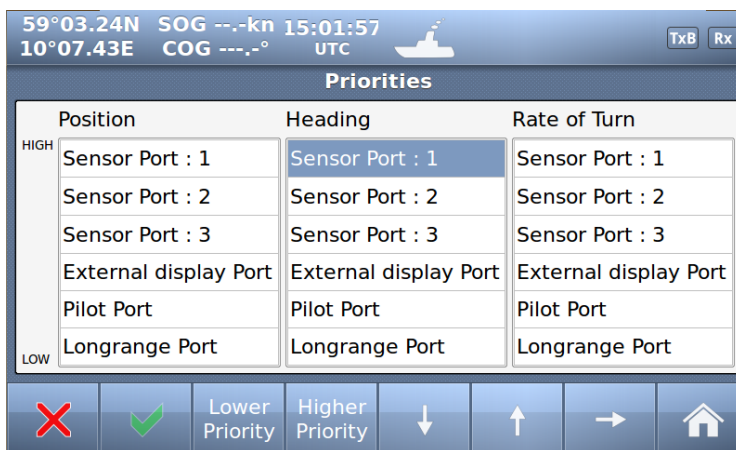

Priorities of Position, Heading and Rate Of Turn can be configured in this window. SOG and COG follows the position priority setting.

Select which "Port" will have lower or higher priority.

10.2.1.6 Port Monitor

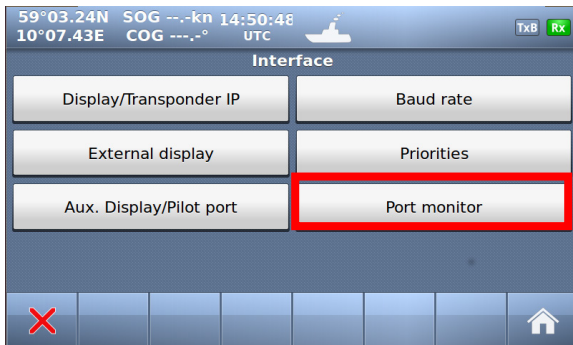

Red square shows button selected to get to next menu

“Port monitor” is an important feature in TR-8000 Display Unit which can help troubleshooting connection issues with different sensors. The “Port monitor” acts as a Terminal window, showing raw data received on a sensor, similar to Windows “Hyperterminal”



First select which “Sensor port” you want to “listen” to

And if a Sensor is connected it could look similar to these:

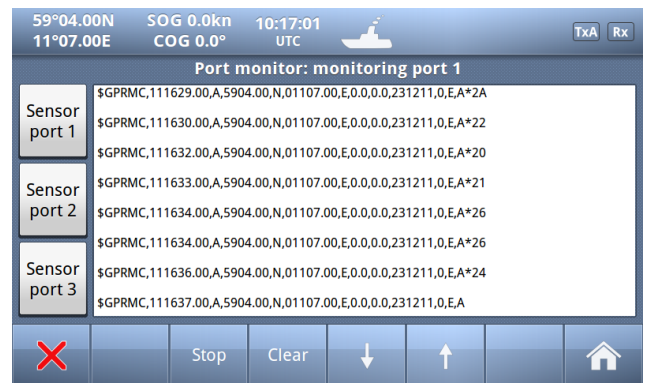
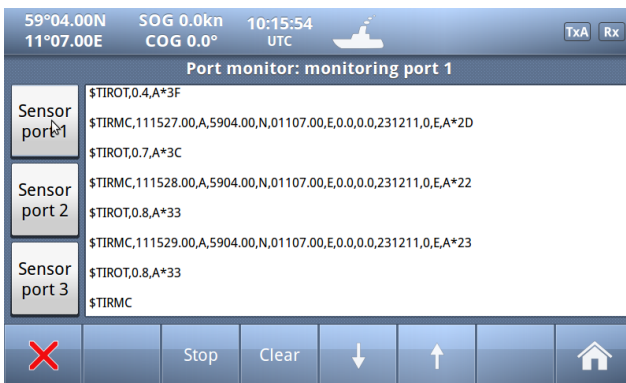

The two screenshots above shows Sensor data which are most probably OK, while left screenshot shows corrupt data from incorrectly connected sensor (Polarity of signals are incorrect)



10.2.2 VHF link/Long Range

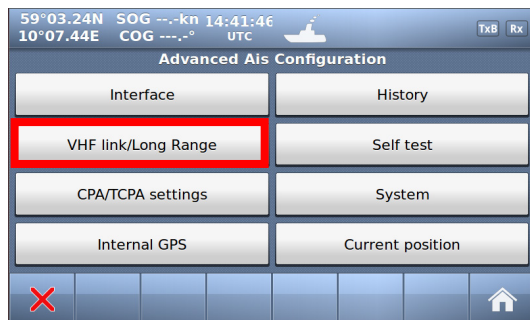

Red square shows button selected to get to next menu

In this menu, configuration of

- Long Range
- VHF Link (Silent ON/OFF)

can be done, In addition to:

- Test VHF link communication
- Display AIS-SART when such equipment are tested

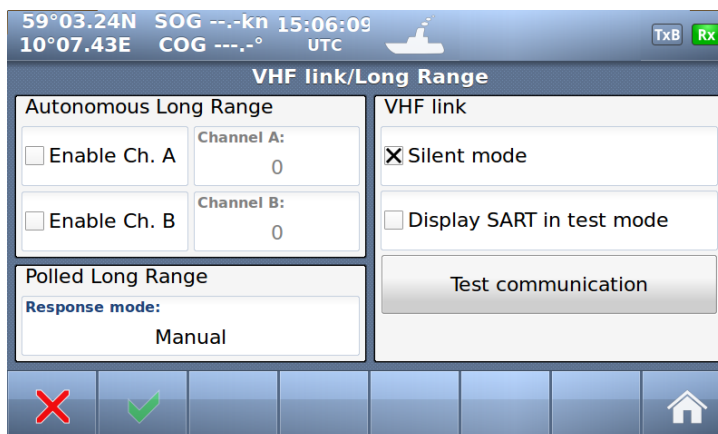

10.2.2.1 Autonomous Long Range

Long Range Broadcast Channel A and B are used for broadcasting positions and ship data to a satellite system. Base Stations are able to temporarily disable the Long Range broadcast functionality of the AIS. The Long Range Broadcast may also be disabled manually by administrator.

10.2.2.2 Polled Long Range

The Polled Long Range system can be configured to reply automatically or wait for acknowledgement from the user. An indication of received LR messages is displayed for the user in either case.

10.2.2.3 Silent mode

The silent mode is a special mode for travelling in areas where the transmission of own position impose risk to the user. When active, no signals are sent from the Transponder unit, but the user is still able to receive information from other vessels.

If the *Silent Mode* is active for more than 15 minutes, the event is logged in the *History Log*.

CAUTION: The *Silent Mode* disables the AIS Transmitter functionality and will make the Vessel invisible on the AIS system and impose a risk to other and own vessels.

10.2.2.4 Display SART in TEST mode

When AIS-SART was introduced as alternative to traditional Radar SART in 2011, it was obvious that testing such equipment could lead to much “noise” on nearby ships AIS Transponders and ECS/ECDIS as this AIS-SART icon/text message would pop up on all nearby vessels within VHF range (5-40 nautical miles). Therefore, revisions in the AIS standards were made so the person who wants to test the AIS on-board the ship, must first activate this menu item before it will be shown on the vessels AIS and ECS/ECDIS or Chart Plotter.

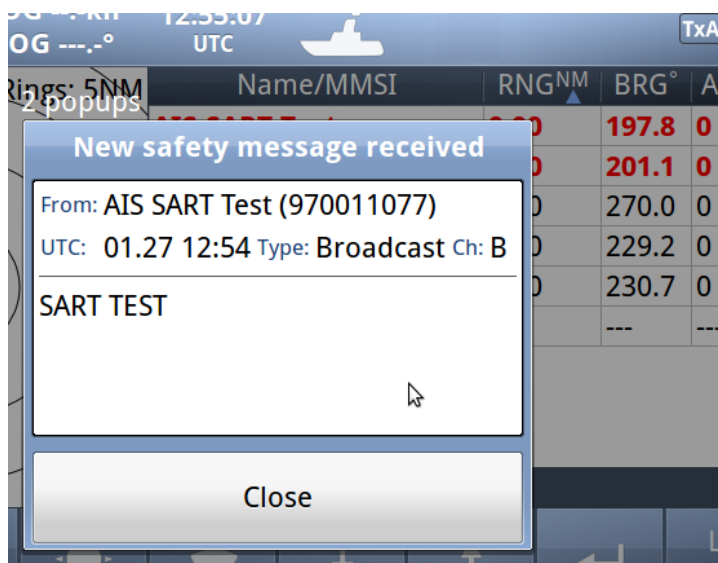

Example showing “Display SART in test mode” and Popup received to be acknowledged by pressing “Close” button

PS! Observe that here are “2 popups” received from 2 different AIS-SARTs and each “popup” must be acknowledged. Also observe that AIS-SARTs are displayed in top of the list in the background, and with RED color.

10.2.2.5 Test Communication

The Communications Test is used to test the VHF communication by transmitting a request for an acknowledgement to another ship. The target is automatically selected by the Display Unit, but the user can choose to select another target as long as the target is a Class A AIS transponder. If the Acknowledgment is not received within 10 seconds, the Communications Test has failed and the user should optionally retry with another target.

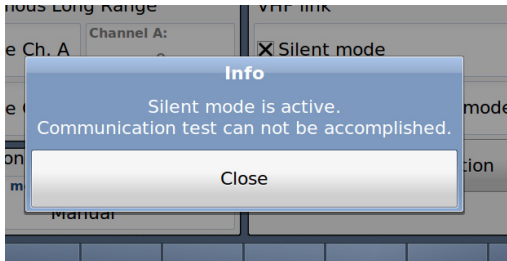

If the TR-8000 is in "Silent mode", it is not possible to perform this test:

If not, we can continue with the test:

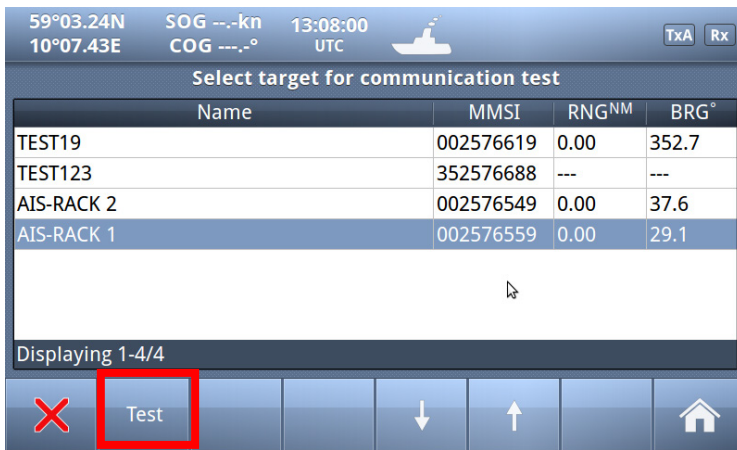

Step #1: Select Target

Step #2: Press "Test"

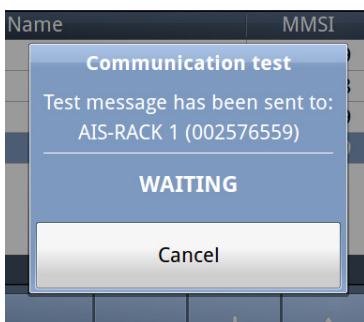

Step #3: Wait until test finished

Success:

or

Failure:

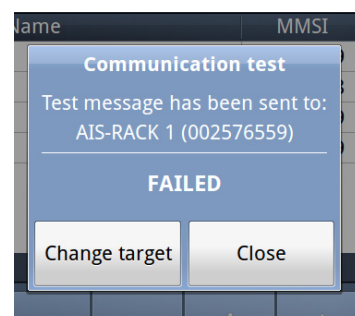
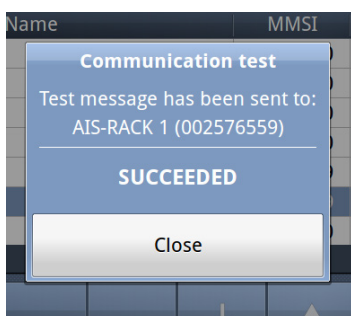

If the TEST fails, we can select another target and redo the test

10.2.3 CPA/TCPA settings

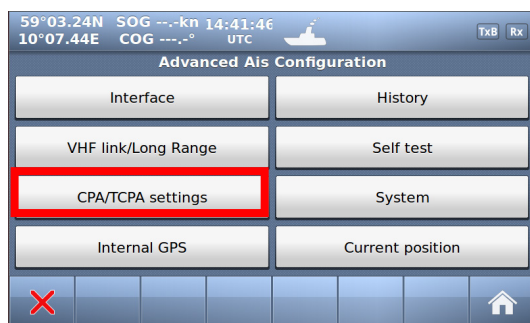

Red square shows button selected to get to next menu

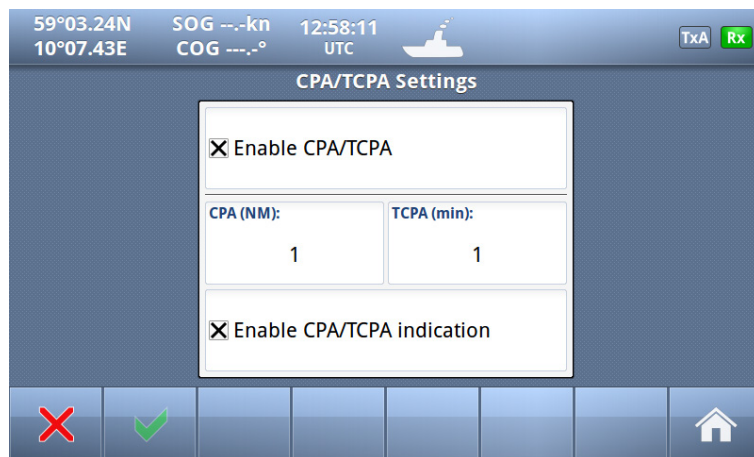

The CPA (Closest Point of Approach) and TCPA (Time to Closest Point of approach) range for which you want to be alerted of AIS targets on a possible collision course with you needs to be set here. You may also disable the CPA/TCPA functionality manually. How the user is alerted is also specified in this menu.

Note that the CPA/TCPA are calculated in the display only. No alarm will be generated to any external equipment. If the AIS is connected to remote systems that will calculate CPA/TCPA based on the realtime information from the AIS, the CPA/TCPA calculations in the display should be turned off.

10.2.4 Internal GPS

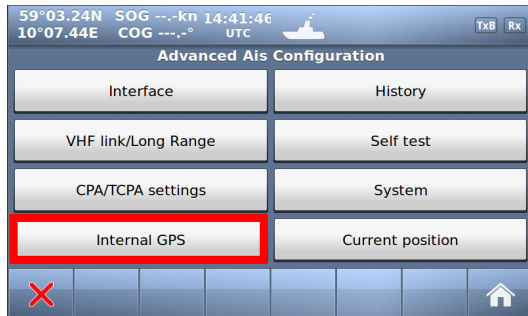

Red square shows  button selected to get to next menu

It is possible to inspect the functionality of the internal GPS receiver by the following parameters:

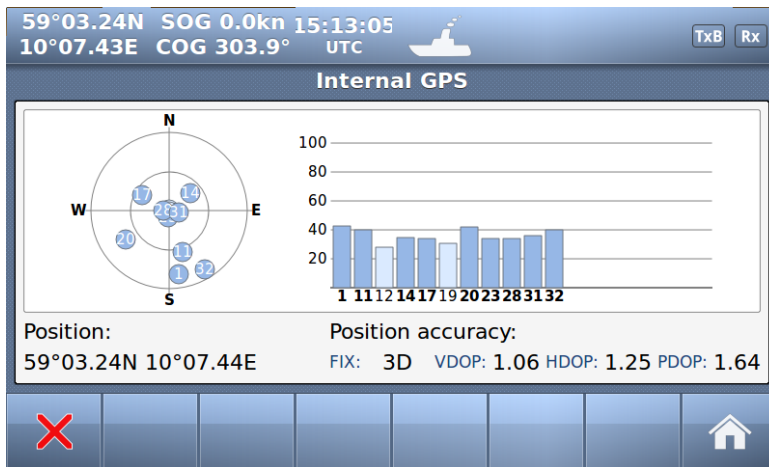

- Satellites in view
- Signal strength
- Position
- Pos. accuracy
- Precision
- Differential mode

10.2.5 History Log

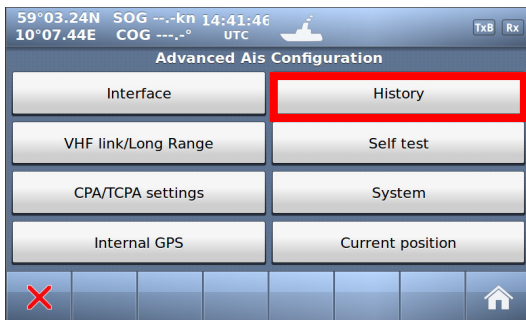

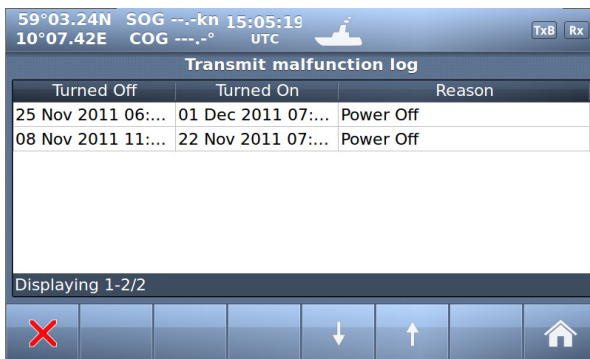

Red square shows  button selected to get to next menu

If the transmitter functionality of the transponder stops functioning for more than 15 minutes, this is logged as an event in the *History Log*.

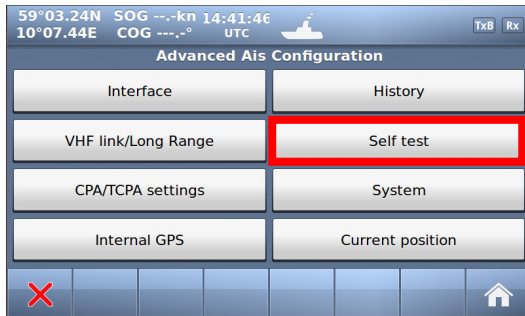

10.2.6 Self Test



Red square shows  button selected to get to next menu

The “Self Test” consist of two different tests, a “Transponder self test” and a “Display self test”:

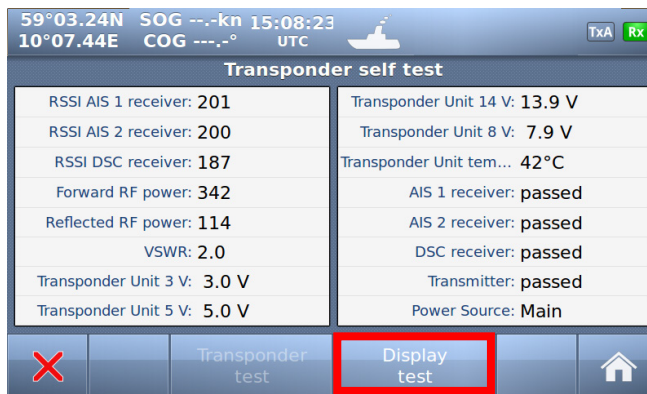

“Transponder self test” measures values of:
Signal strength (RSSI.. 0-255)

- RF Power (Forward+ Reflected :0-512)
- Antenna matching (VSWR)
- Voltages (3, 5, 8 and 14v)
- Receivers status
- Transmitter status
- Power source (Main, Backup)

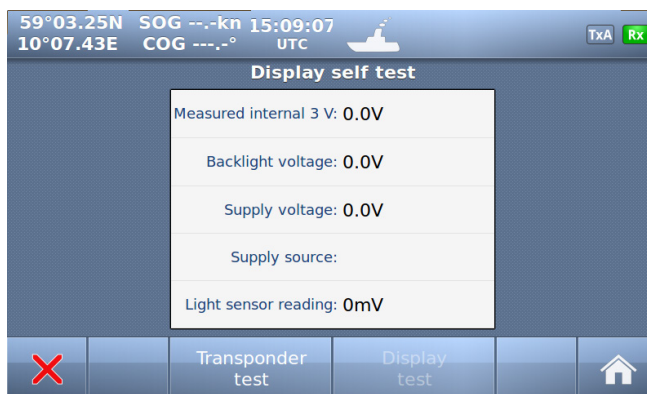

When “Display test” is selected, this window is shown with measurement:

- Voltages
- Supply source (Power source)
- Light sensor reading (If automatic display adjustment are activated [option])

10.2.7 System

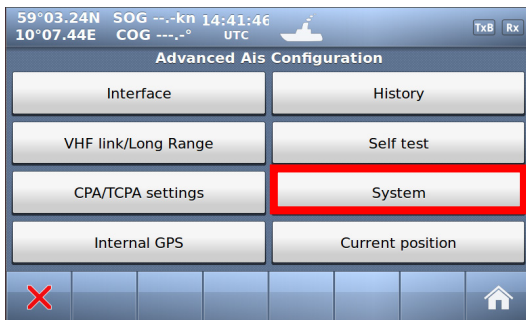

Red square shows  button selected to get to next menu

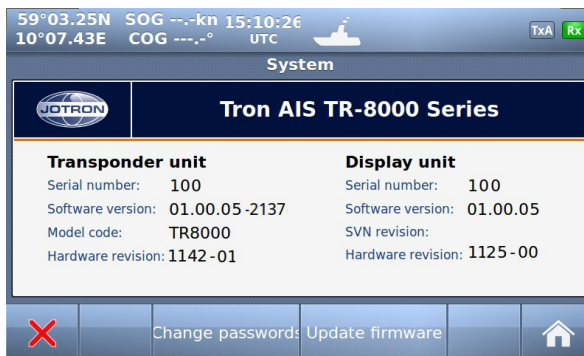

In this window you can read information about :

- Serial number
- Software
- Hardware

of both Display and Transponder unit

In addition you may select the buttons:

- Change password
- Update firmware

10.2.7.1 Change password

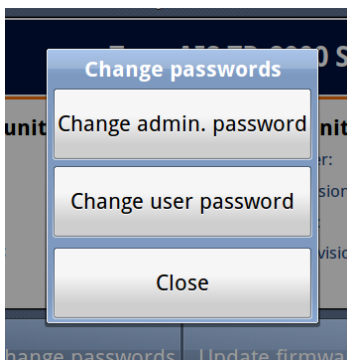

If you select “Change password”, you can select between

- Admin password
- User password

NOTE: You must have access to “Admin password” to change the “User password”

10.2.7.2 Update Firmware

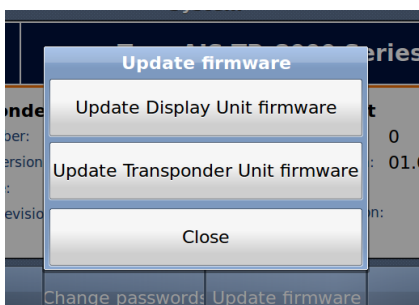



If you select “Update firmware”, you can select between

- Display unit firmware
- Transponder unit firmware

NOTE: Update of Firmware shall only be done by Jotron trained dealers, distributors & service agents.

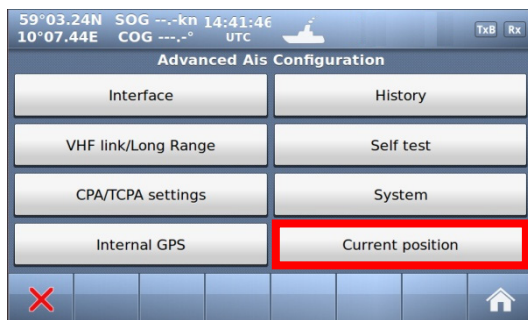
10.2.8 Current position



Red square shows  button selected to get to next menu

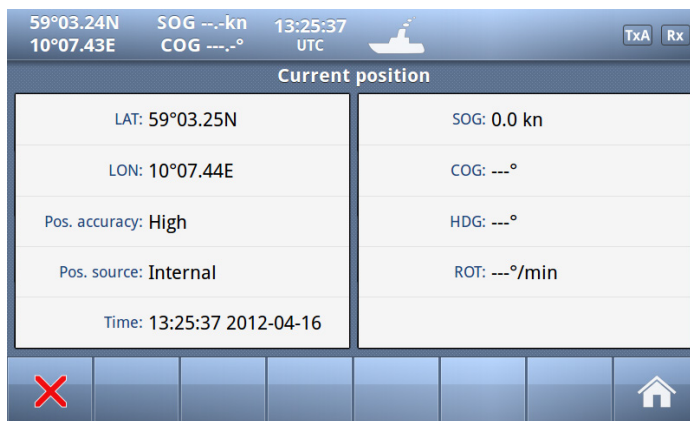

The "Current position" will show information about:

- Latitude
- Longitude
- Pos Accuracy (High/Low)
- Pos Source (Internal/External)
- Time & Date
- SOG (Speed over Ground)
- COG (Course Over Ground))
- HDG (Heading)
- ROT (Rate Of Turn)

11 Menu tree



Configuration menu

- Own Ship data (Name, MMSI, IMO number, Antenna Position, Type of Vessel)
- Display Settings (Sleeping targets)
- Regions
 - Add region
 - View regions
- Alarms
- Indicators
- Advanced
 - Interface
 - Display/Transponder IP
 - External Display
 - Aux. Display/Pilot Port
 - Baud rate
 - Priorities
 - Port Monitor (monitor sensor connections)
 - VHF link / Long Range
 - CPA/TCPA settings
 - Internal GPS
 - History
 - Self Test
 - System (System information, serial no. and revisions)
 - Change Passwords
 - Update firmware
 - Current Position



Safety Message Menu

- Toggle between sent and received messages
- Write New message
- Select message in list (up and down arrows)
- Resend a selected Sent message (if any) or reply on a selected Received message (if any)



Display options

- Day / Night mode
- Dimming



Voyage Data

- Configuration of Navigation Status, Destination, ETA, Draught, Cargo category and number of Persons aboard.

12 List of VHF Channels

Channel	Frequency	Channel	Frequency	Channel	Frequency	Channel	Frequency
6	156.3000	1021	157.0500	1279	156.9775	2219	161.5625
8	156.4000	1022	157.1000	1280	157.0375	2220	161.6125
9	156.4500	1023	157.1500	1281	157.0875	2221	161.6625
10	156.5000	1024	157.2000	1282	157.1375	2222	161.7125
11	156.5500	1025	157.2500	1283	157.1875	2223	161.7625
12	156.6000	1026	157.3000	1284	157.2375	2224	161.8125
13	156.6500	1027	157.3500	1285	157.2875	2225	161.8625
14	156.7000	1028	157.4000	1286	157.3375	2226	161.9125
15	156.7500	1060	156.0250	1287	158.3875	2227	161.9625
16	156.8000	1061	156.0750	2001	160.6500	2228	162.0125
17	156.8500	1062	156.1250	2002	160.7000	2260	160.6375
67	156.3750	1063	156.1750	2003	160.7500	2261	160.6875
68	156.4250	1064	156.2250	2004	160.8000	2262	160.7375
69	156.4750	1065	156.2750	2005	160.8500	2263	160.7875
70	156.5250	1066	156.3250	2007	160.9500	2264	160.8375
71	156.5750	1078	156.9250	2018	161.5000	2265	160.8875
72	156.6250	1079	156.9750	2019	161.5500	2266	160.9375
73	156.6750	1080	157.0250	2020	161.6000	2278	161.5375
74	156.7250	1081	157.0750	2021	161.6500	2279	161.5775
75	156.7750	1082	157.1250	2022	161.7000	2280	161.6375
76	156.8250	1083	157.1750	2023	161.7500	2281	161.6875
77	156.8750	1084	157.2250	2024	161.8000	2282	161.7375
208	156.4125	1085	157.2750	2025	161.8500	2283	161.7875
209	156.4625	1086	157.3250	2026	161.9000	2284	161.8375
210	156.5125	1087	157.3750	2027	161.9500	2285	161.8875
211	156.5625	1088	157.4250	2028	162.0000	2286	161.9375
212	156.6125	1201	156.0625	2060	160.6250	2287	161.9875
213	156.6625	1202	156.1125	2061	160.6750		
214	156.7125	1203	156.1625	2062	160.7250		
215	156.7625	1204	156.2125	2063	160.7750		
216	156.8125	1205	156.2625	2064	160.8250		
217	156.8625	1206	156.3125	2065	160.8750		
267	156.3875	1207	156.3625	2066	160.9250		
268	156.4375	1218	156.9125	2078	161.5250		
269	156.4875	1219	156.9625	2079	161.5750		
270	156.5375	1220	157.0125	2080	161.6250		
271	156.5875	1221	157.0625	2081	161.6750		
272	156.6375	1222	157.1125	2082	161.7250		
273	156.6875	1223	157.1625	2083	161.7750		
274	156.7375	1224	157.2125	2084	161.8250		
275	156.7875	1225	157.2625	2085	161.8750		
276	156.8375	1226	157.3125	2086	161.9250		
277	156.8875	1227	157.3625	2087	161.9750		
1001	156.0500	1228	157.4125	2088	162.0250		
1002	156.1000	1260	156.0375	2201	160.6625		
1003	156.1500	1261	156.0875	2202	160.7125		
1004	156.2000	1262	156.1375	2203	160.7625		
1005	156.2500	1263	156.1875	2204	160.8125		
1007	156.3500	1264	156.2375	2205	160.8625		
1018	156.9000	1265	156.2875	2206	160.9125		
1019	156.9500	1266	156.3375	2207	160.9625		
1020	157.0000	1278	156.9375	2218	161.5125		

Channel 2087 = Channel 87B Channel 2088 = Channel 88B

13 Complied Standards

The TR-8000 AIS system complies with the following standards:

IMO Resolution MSC.694(17) – *General Requirements for Shipborne Radio Equipment forming part of the Global Maritime Distress and Safety System (GMDSS) and for Electronic Navigational Aids*

IMO Resolution MSC.74(69) *Annex 3 Recommendation on performance standards for AIS*

IMO Resolution MSC.191(79) – *Performance standards for the presentation of navigation related information on shipborne navigational displays*

ITU-R M.1371-4 (Class A), 2010 – *Technical characteristics for an automatic identification system using time-division multiple access in the VHF maritime mobile band*

ITU-R M.825-3, 1998 - *Characteristics of a transponder system using digital selective calling techniques for use with vessel traffic services and ship-to-ship identification*

ITU-R M.1084-4 – *Interim solutions for improved efficiency in the use of the band 156-174 MHz by stations in the maritime band*

IEC 61993-2 Ed.2, 2012 - *Maritime navigation and radio communication equipment and systems – Automatic Identification Systems (AIS), Part 2: Class A ship borne equipment of the universal automatic identification system (AIS) – Operational and performance requirements, methods of test and required results*

IEC 61108-1 Ed.2, 2003 – *Maritime navigation and radio communication equipment and systems – Global navigation satellite systems (GNSS)*

IEC 62288 Ed.2, 2014 – *Maritime navigation and radio communication equipment and systems – Presentation of navigation-related information on shipborne navigational displays – General requirements, methods of testing and required test results*

IEC 61162-1 Ed.4, 2010 - *Maritime navigation and radio communication equipment and systems – Digital interfaces – Part 1: Single talker and multiple listeners*

IEC 61162-2 Ed.1, 1998 - *Maritime navigation and radio communication equipment and systems – Digital interfaces – Part 2: Single talker and multiple listeners, high-speed transmission*

IEC 60945 Ed.4, 2002 incl. Corr.1, 2008 – *Maritime navigation and radio communication equipment and systems – General requirements – Method of testing and required test results*

14 Outline Drawings

14.1 TR-8000 Transponder Unit

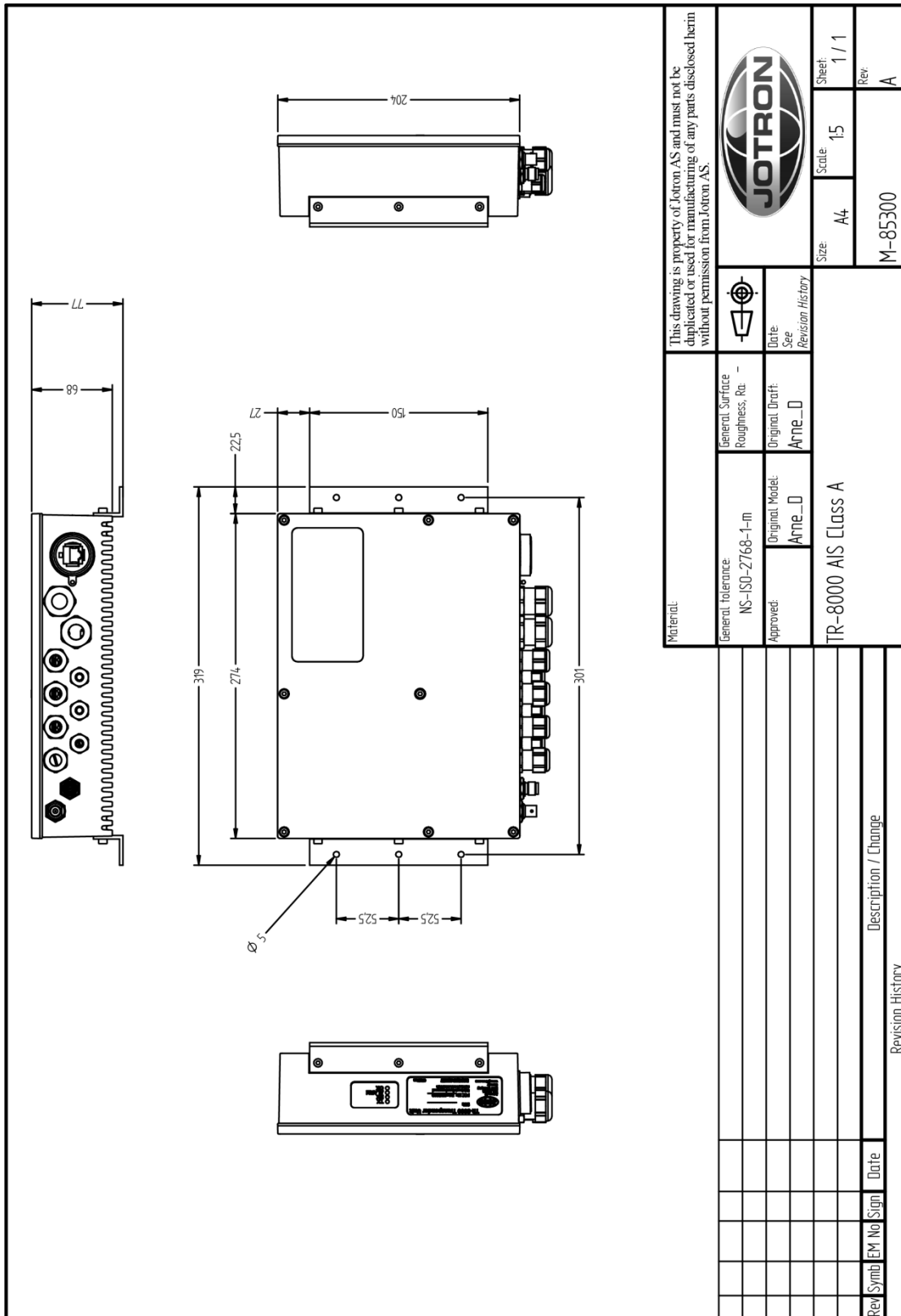
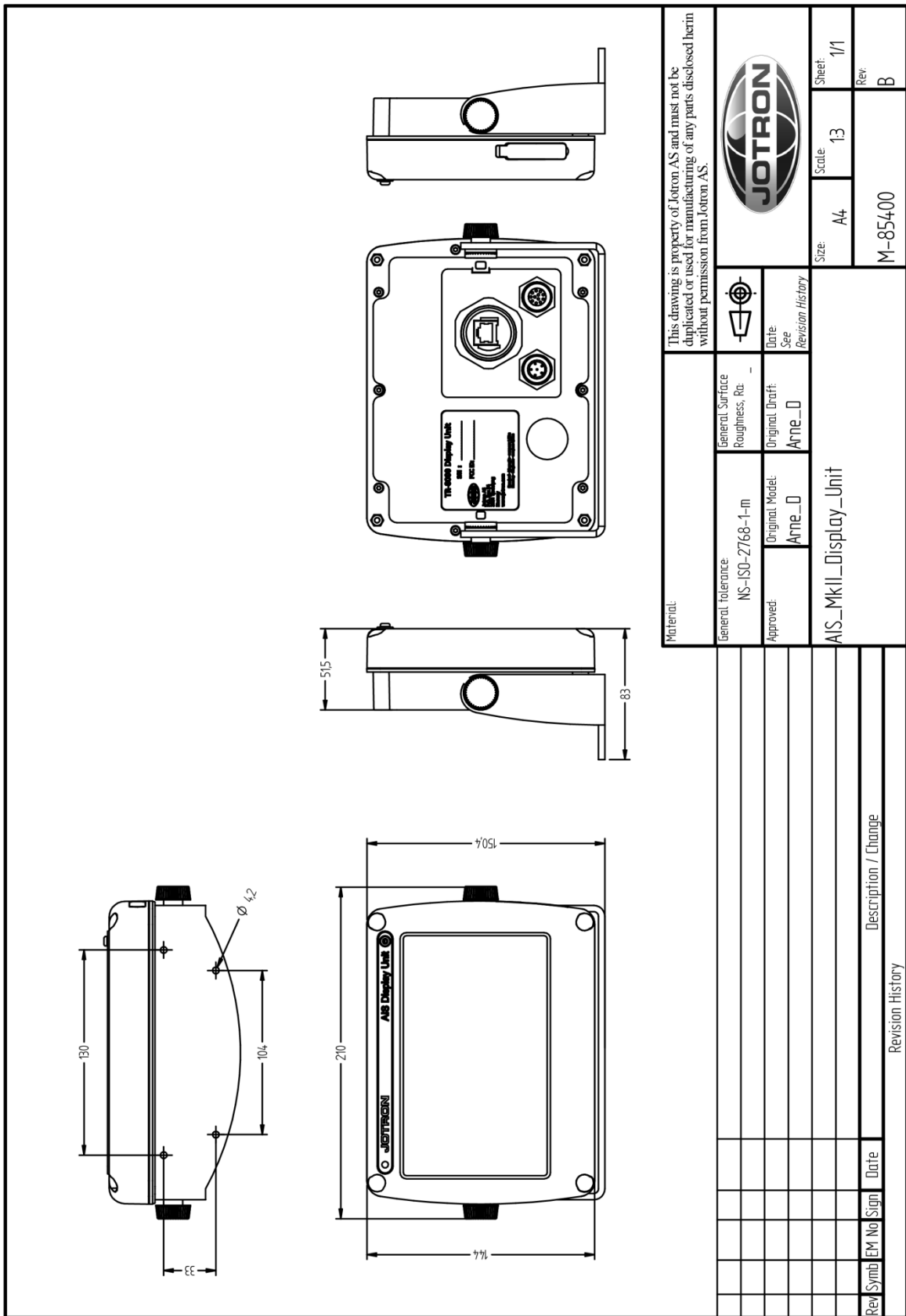

Figure 14-1 TR-8000 Transponder Unit- mechanical dimensions

14.2 TR-8000 Display Unit, Desktop or Overhead mount



Material:		This drawing is property of Jotron AS and must not be duplicated or used for manufacturing of any parts disclosed herein without permission from Jotron AS.	
General Tolerance:	NS-ISO-2768-1-m	General Surface Roughness, Ra:	-
Approved:	Arne_D	Original Draft:	Arne_D
Date:		Date:	
Revision History		Revision History	
AIS_MkII_Display_Unit			
Size:	A4	Scale:	13
Sheet:	1/1	Rev:	B
M-85400			
Revision History			
Rev Symb	EM No	Sign	Date
Description / Change			

14.3 TR-8000 Display Unit, Flush/Panel mount

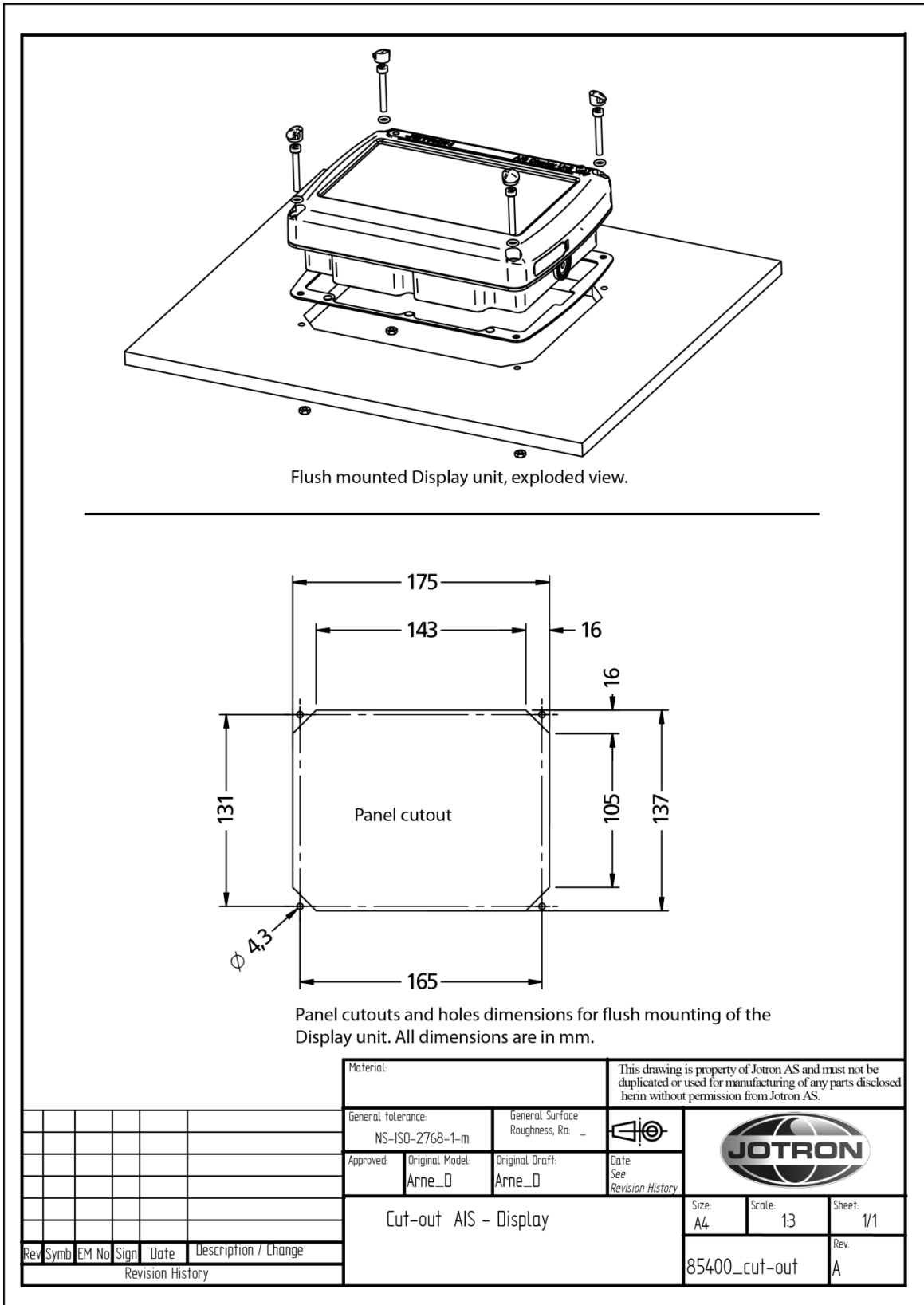

Figure 14-3 TR-8000 Display Unit - Flush Mount Cutout dimensions

14.4 SANAV – GPS Marine Antenna



Figure 14-4 Sanav SA-200 GPS Antenna

GPS Marine Antenna with Low Noise Amplifier

SA-200 is designed for the Marine Vessels mast or tall buildings that require long extra cables (up to 50 meters) without signal constraint to the GPS receivers.

MODEL: SA-200

Overview

SA-200 is the integration of the high performance GPS patch antenna and a state-of-the-art low noise amplifier into an extremely compact/fully waterproof enclosure and when connected to a GPS receiver with +5VDC antenna power it can provide excellent antenna signal amplification and out-band filtering with rejection for that receiver.

Specification

Physical Constructions:

Constructions:	Polycarbonate radome enclosure (top & bottom base with rubber O-ring inbetween) Center feeds TNC connector for antenna output
Dimensions:	4.5" in diameter & 2.9" in height
Weight:	220 grams (without cable)
Standard Mounting:	External flagpole mount (11cm-height threaded mast), an optional accessory kit
Optional mounting plate:	1. Cabin roof-mount with stainless steel base & shaft 2. Rail side mount with stainless rod

15 Abbreviations and Definitions

ACK	Acknowledge
AIS	Automatic Identification System - A shipborne broadcast transponder system in which ships continually transmit their position, course, speed and other data to other nearby ships and shoreline authorities on a common VHF radio channel.
AIS-SART	Automatic Identification System-Search And Rescue Transponder
AtoN	Aid to Navigation
BAUD	Transmission rate unit of measurement for binary coded data (bit per second).
BNC	Bayonet Neill-Concelman connector – common type of RF connector used for coaxial cable
BRG	Bearing
CPA	Closest Point of Approach
COG	Course Over Ground – Course made good relative to the sea bed.
DSC	Digital Selective Calling
DGNSS	Differential GNSS
DGPS	Differential GPS – A method of refining GPS position solution accuracy by modifying the locally computed position solution with correction signals from an external reference GPS CDU (monitor).
ECDIS	Electronic Chart Display and Information System for navigation approved to be used without paper charts
ECS	Electronic Chart System
EPFS	Electronic Position Fixing System (GPS is mostly used)
ETA	Estimated Time of Arrival. Calculated on basis of the distance to the destination and the current (or estimated) speed.
FM	Frequency Modulation - The method by which a signal offsets the frequency in order to modulate it on a data link.
GNSS	Global Navigation Satellite System – A common label for satellite navigation systems (such as GPS and GLONASS).
GPS	Global Positioning System – The NAVSTAR Global Positioning System, which consists of orbiting satellites, a network of ground control stations, and user positioning and navigation equipment. The system has 24 satellites plus 3 active spare satellites in six orbital planes about 20,200 kilometers above the earth.
GLONASS	A satellite navigation system developed and operated by Russia.

GMT	Greenwich Mean Time
GMDSS	Global Maritime Distress Safety System
HDG	Heading - The direction, in which the vessel is pointed, expressed as angular distance from north clockwise through 360 degrees. HEADING should not be confused with COURSE. The HEADING is constantly changing as the vessel yaws back and forth across the course due to the effects of sea, wind, and steering error.
IALA	International Association of Marine Aids to Navigation and Lighthouse Authorities
IEC	International Electro-technical Commission
IEC 61162-1	Maritime navigation and radio communication equipment and systems – Digital interfaces Single Talker- Multiple listeners: Closely related to NMEA0183 version 2.3, communication at 4800 baud. Definition of both electrical interface and protocol to be used.
IEC 61162-2	Maritime navigation and radio communication equipment and systems – Digital interfaces Single Talker- Multiple listeners, High speed transmission: Closely related to NMEA0183HS version 2.3, communication at 34800 baud. Definition of both electrical interface and protocol to be used.
IMO	International Maritime Organization
IP	Internet Protocol (IP) is the central, unifying protocol in the TCP/IP suite. It provides the basic delivery mechanism for packets of data sent between all systems on an internet, regardless of whether the systems are in the same room or on opposite sides of the world. All other protocols in the TCP/IP suite depend on IP to carry out the fundamental function of moving packets across the internet.
ISGOTT	International Safety Guide for Oil Tankers and Terminals
ITU	International Telecommunication Union
LAN	Local Area Network
LED	Light Emitting Diode
LCD	Liquid Crystal Display
LR	Long Range
NMEA	National Marine Electronics Association – The NMEA electronics interface specifications have been developed under the auspices of the Association. The NMEA 0183 is an internationally recognized specification for interfacing marine electronics. NMEA 0183 version 2.3 is almost identical to IEC 61162-1.
MKD	Minimum Keyboard and Display
MMSI	Maritime Mobile Service Identity

RCC	Rescue Coordination Centre
RF	Radio Frequency
RMS	ROOT MEAN SQUARED – A statistical measure of probability stating that an expected event will happen 68% of the time. In terms of position update accuracy, 68 position updates out of 100 will be accurate to within specified system accuracy.
ROT	Rate Of Turn
RNG	Range
RX	RX is the telegraph and radio abbreviation for “receive”
SAR	Search And Rescue
S/N	Signal-to-Noise ratio (SIN). Quantitative relationship between the useful and non-useful part of the received satellite signal. A high SIN indicates a good receiving condition.
SOG	Speed Over Ground – Speed in relation to the seabed.
SOTMA	Self Organized Time Division Multiple Access -An access protocol, which allows autonomous operation on a data link while automatically resolving transmission conflicts.
TCP	Transmission Control Protocol – Provides a reliable byte-stream transfer service between two end points on an internet. TCP depends on IP to move packets around the network on its behalf.
TCP/IP	TCP/IP is a name given to the collection (or <i>suite</i>) of networking protocols that have been used to construct the global Internet. The protocols are also referred to as the DoD (<i>dee-oh-dee</i>) or Arpanet protocol suite because their early development was funded by the Advanced Research Projects Agency (ARPA) of the US Department of Defense (DoD).
TCPA	Time to Closest Point of Approach
TI	Turn Indicator
TNC	Threaded Neill-Concelman connector – common type of RF connector used for coaxial cable
TX	TX is the telegraph and radio abbreviation for “transmit”
UDP	User Datagram Protocol – Provides a packetized data transfer service between end points on an internet. UDP depends on IP to move packets around the network on its behalf.
UTC	Universal Time Coordinated – Greenwich mean time corrected for polar motion of the Earth and seasonal variation in the Earth's rotation.
VDC	Volt DC
VDL	VHF Data Link

VHF Very High Frequency – A set of frequencies in the MHz region

VSWR Voltage standing wave ratio

16 Service Procedure

WARRANTY CLAIM

Warranty claims are valid until 2 years from delivery from our warehouse. The warranty is valid as long as service is carried out by authorized Jotron distributors or agents.

All products are warranted against workmanship and factory defect, in material. Any warranty claims must be sent to Jotron, in writing.

Jotron reserve the right to decide whether a defective unit is within warranty terms and conditions.

If Jotron make a decision of repairing a defective product, a written description of the claim and a Jotron RMA number, should follow the unit when returning it back to Jotron's factory.

Please be noted that un-protective electronics board **MUST** be packed in antistatic bag, before returning to Jotron's factory.

Any costs related to transportation and/or workmanship linked up to the return of the product being repaired shall be covered by the customer.

Jotron's obligations during warranty replacement;
Replace defective unit, including any programming
Delivery terms: DAP Incoterms 2010 by regular freight to "Place" (Airport)

Service agent's obligations during warranty claims:
Supply replacement unit from own stock if available
If agreed, return defective unit to Jotron
Electronic units must be shipped in antistatic bags or covered with Jotron's plastic cover

SERVICE – NOT WARRANTY CLAIM

Service, such as testing, installation, programming, replacement is provided by an authorized Jotron service agent. Jotron do not meet the cost for services mentioned above. Distributor or service agent should stock the most commonly needed spare parts.

16.1 Tron TR-8000 AIS Installation – registration form

Vessel name		IMO Number	
Flag State		MMSI Number	
Owner / Company		Radio Call Sign	
On-Board Contact Name		Telephone Number(s)	Office:
			GSM:
Superintendents Name		Telephone Number(s)	Office:
			GSM:
Type of Vessel		Gross Registered Tonnage	GWT
L.O.A.	mtrs	Beam	mtrs
Comments:			
TR-8000 Transponder unit, serial number:			
TR-8000 Display unit, serial number:			

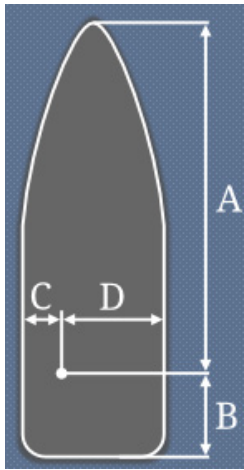
	Antenna Location		GNSS Antenna connected directly to TR-8000 (Internal)
		GNSS Antenna connected to External Position Source	
	A=Distance to Bow	mtrs	mtrs
	B=Distance to Stern	mtrs	mtrs
	C=Distance to Port Side	mtrs	mtrs
D=Distance to Starboard side	mtrs	mtrs	

Installation completed and successfully commissioned by:

Technician, (type name)			
Service provider / company			
Place	Date	Signature	

Please fill in with capital letters

This form must be sent to Jotron AS, beacon@jotron.com or Fax.: + 47 33 12 67 80 (Att: Service department) in order to have a valid 24 months product warranty

16.2 Trouble Description Form

For better to help you if your system fails, please give as much information as possible in the following tables:

Transponder Unit Information	Information from System Menu
Serial number	
Software version	
Model code	
Hardware revision	

Display Unit Information	Information from System Menu
Serial number	
Software version	
SVN revision	
Hardware revision	

Transponder Unit Connections:	Equipment:
Sensor 1	
Sensor 2	
Sensor 3	
Ext Display Port (RS-422/RS-232/LAN)?	
Pilot Port	
Long Range Port	
DGNSS Data Port	

Display Unit Connections:	Equipment:
Pilot Port	

Trouble Description:

17 SERVICE AGENTS

Please look at www.jotron.com for Marine Service Agents.

18 List of Figures

Figure 8-1 Transponder Unit, exploded view. Opening of outer Lid	38
Figure 8-2 Desktop mounted Display Unit.....	39
Figure 8-3 Roof mounted Display Unit	40
Figure 8-4 Flush mounted Display Unit, exploded view.	41
Figure 8-5 Horizontal separation distance.....	42
Figure 8-6 Vertical separation and distance from mast or other object of metal. For best isolation between antennas, place directly underneath with no horizontal separation.	42
Figure 8-7 Connection cable for interconnection between the Transponder and the Display Unit	46
Figure 8-8 Block diagram of typical connections.....	47
Figure 8-9 Transponder with lid removed, lid screws highlighted	48
Figure 8-10: Typical connections to a TR-8000 transponder, dashed lines shows options.....	49
Figure 8-11: Label inside transponder with corresponding table showing details about each connection. It is coloured to differentiate sensors, display/pilot, alarm and DGNSS beacon interface.....	50
Figure 8-12 Use the supplied orange screwdriver to open the terminals.....	51
Figure 8-13 External display connections.....	53
Figure 8-14 Ethernet RJ45 connector	53
Figure 8-15 Pilot plug with cable	54
Figure 8-16 AMP 206486-1 (Pilot Plug) pinout	54
Figure 8-17 Typical Alarm connection	55
Figure 8-18 Partno.: 86870, Pilot plug cable, Display Unit	59
Figure 8-19 Partno.: 86581, Power cable, Display Unit	59
Figure 8-20 AMP 206486-1 Pinout	59
Figure 8-21 Ethernet RJ45 connector	60
Figure 10-1 Typical Alarm connection	79
Figure 10-2 Pilot port connection, TR-8000 Transponder unit.....	84
Figure 10-3 Pilot port connection, TR-8000 Display unit (rear).....	84
Figure 10-4 Pilot port cable, Display unit	84
Figure 10-5 Pilot port cable, Transponder unit	84
Figure 14-1 TR-8000 Transponder Unit- mechanical dimensions	100
Figure 14-2 TR-8000 Display Unit- Mechanical Dimensions.....	101
Figure 14-3 TR-8000 Display Unit - Flush Mount Cutout dimensions.....	102
Figure 14-4 AIS Antenna Splitter Datasheet	Error! Bookmark not defined.
Figure 14-5 Sanav SA-200 GPS Antenna	103



CONTACT INFORMATION

Jotron AS (HQ)

P.O.Box 54
3281 Tjodalyng
Norway
Tel: +47 33 13 97 00
Fax: +47 33 12 67 80
sales@jotron.com

Jotron AS

P.O.Box 23
3195 Skoppum
Norway
Tel: +47 33 13 97 00
Fax: +47 33 12 67 80
sales@jotron.com

Jotron UK Ltd.

Crosland Park
Cramlington
NE23 1LA
United Kingdom
Tel: +44 (0) 1670 712000
Fax: +44 (0) 1670 590265
sales@jotron.com

Jotron Asia Pte. Ltd.

19 Loyang Way
Changi Logistics Centre
Rear Office Block 04-26
Singapore 508724
Tel: +65 65426350
Fax: +65 65429415
sales@jotron.com

Jotron USA, Inc.

10645 Richmond Avenue
Suite 170
Houston, TX 77042
USA
Tel: +1 713 268 1061
Fax: +1 713 268 1062
sales@jotron.com

